

Power Ring Film Capacitor 500 μF , 500 Vdc

The 700A373 Power Ring assembly is a 500 μF , 500 Vdc dual-winding DC Link Capacitor integrated with a laminar bus. The assembly has an ESR of 410 $\mu\Omega$ at 20 kHz, an ESL less than 12 nH, and a life of more than 10,000 hours at a typical drive cycle for an 80-120 kW inverter.

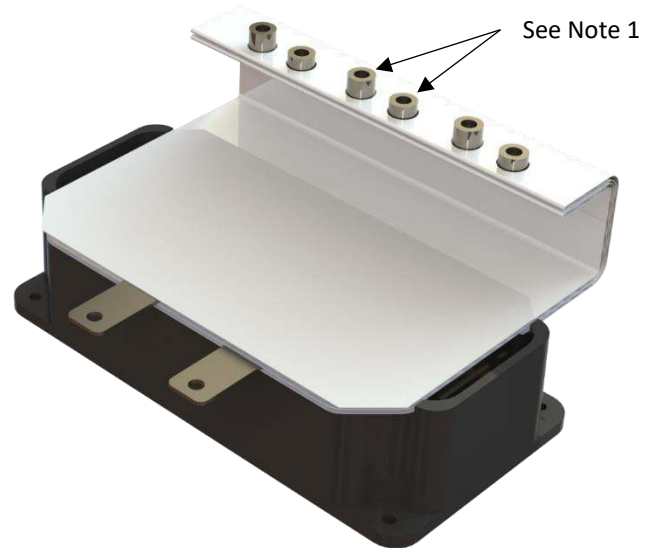

Electrical Specifications

Part #:	700A373
Capacitance/Tolerance:	500 μF $\pm 10\%$
DC Voltage Rating:	500 Vdc
Dielectric:	Metallized polypropylene film
ESL at IGBT Terminals:	Less than 12 nH
Typical ESR vs. Frequency:	410 $\mu\Omega$ at 20 kHz
Continuous DC Voltage Rating:	500 Vdc up to 85°C (de-rate linearly from 500 Vdc to 300 Vdc from 85°C to 105°C)
Maximum DC Voltage:	Units 100% tested at DC voltage of 600 Vdc for 2 minutes at 25°C
Operating Temperature:	-40°C to +105°C
Maximum Peak Current:	250 Arms (not to exceed 2 minutes and 85°C hotspot at 500 Vdc)

Mechanical Specifications

Dimensions:	See layout drawing for details
Bus:	Tin plated copper, 0.060" (1.50 mm) thick
Packaging:	Polycarbonate enclosure encapsulated with RTV
IGBT Connection Type:	Thru-hole bushing connections ¹ for Infineon HybridPACK™ Drive and OnSemi VE-Trac™ Direct.
Construction:	Dual windings integrated to a laminar bus
Marking:	
APCS	APCS company identification
700A373	Part number
500 μF $\pm 10\%$	Capacitance value and tolerance
500 Vdc	DC voltage rating
yyww-lot#-unit	Serial number (date code, lot number, unit number)

1. Bushing connections ship loose to be assembled by customer.

Rating Curve:

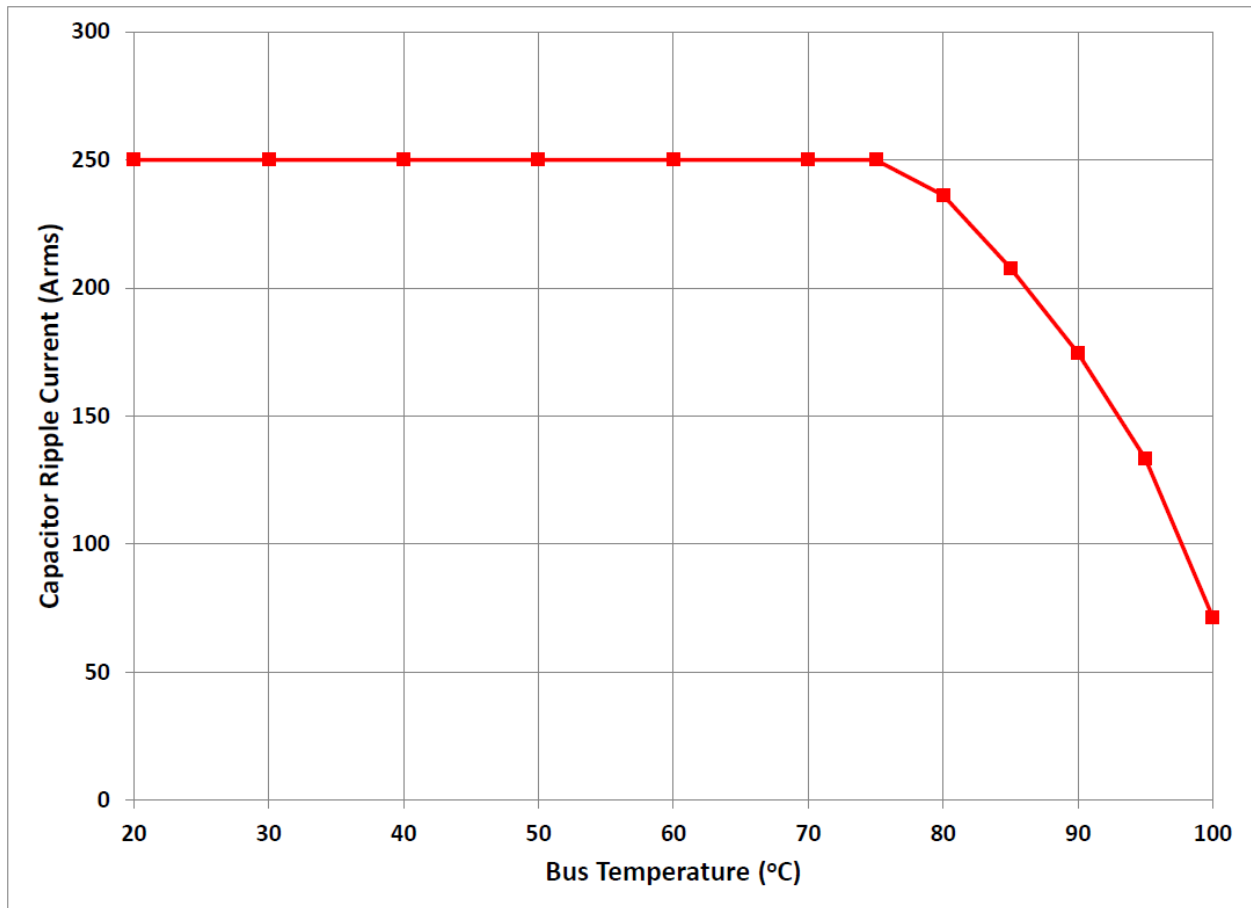

Ripple current versus bus temperature for 10,000-hour life with continuous operation at 450V.

Layout Details:

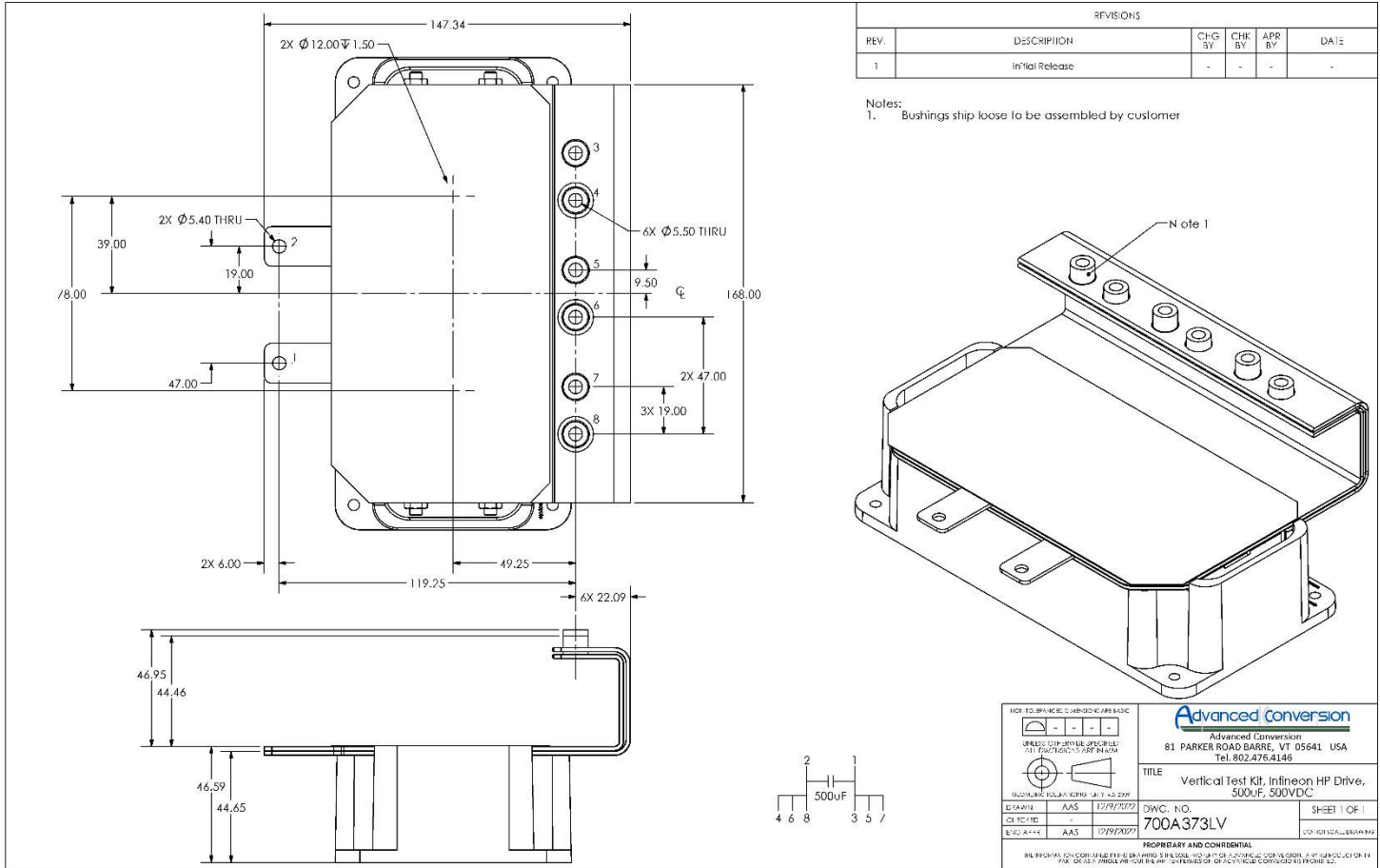

Revision Table		
Revision	Description	Date
Rev 1	Initial release	12/12/2022

Advanced Conversion
81 Parker Road • Barre, VT 05641 USA
Tel: 802-661-3450
Web: www.advanced-conversion.com

Advanced Conversion reserves the right to amend design data



At the Leading Edge of Film Capacitor Technology