

# Genesys™

IEEE488.2 SCPI (GPIB) Multi-Drop  
Interface Option



*User Manual*

**TDK-Lambda**

USER MANUAL FOR  
**IEEE PROGRAMMING INTERFACE**  
**FOR GENESYS™**  
**POWER SUPPLIES**

Manual Supplement

Refer to the Genesys™ Technical Manual for information on installing the power supply, safety requirements, specifications, operating the front panel, using the serial (RS-232/485) programming and the analog (J1) programming .

This page intentionally left blank

**Table of Contents**

**1. THE DIGITAL (IEEE 488.2 SCPI) PROGRAMMING OPTION..... 1**

1.1 INTRODUCTION .....1

1.2 SCOPE OF MANUAL.....1

1.3 CONFIGURATION.....1

1.4 GLOSSARY.....1

1.5 USING DIGITAL PROGRAMMING .....2

    1.5.1 THE IEEE-488.2 INTERFACE ..... 2

1.6 POINT-TO-POINT MODE vs MULTI DROP MODE .....2

1.7 CONFIGURING THE IEEE INTERFACE.....3

    1.7.1 SETTING THE POWER SUPPLY AND IEEE SELECT SWITCH ..... 3

    1.7.2 CONFIGURING THE IEEE CONTROLLER ..... 3

1.8 CONFIGURING THE SUPPLIES.....4

1.9 THE INTERFACE INPUT BUFFER .....4

1.10 GETTING STARTED WITH THE SOFTWARE.....4

    1.10.1 EXAMPLE SESSION USING THE 'IBIC' CONSOLE ..... 4

    1.10.2 EXAMPLE PROGRAM WRITTEN IN VISUAL BASIC ..... 5

    1.10.3 EXAMPLE PROGRAM WRITTEN IN LABVIEW ..... 6

**2. PROGRAMMING COMMANDS ..... 7**

2.1 COMMAND NOTES.....7

2.2 PROGRAMMING AND MESUREMENT COMMANDS .....7

    2.2.1 PROGRAM OUTPUT VOLTAGE ..... 7

    2.2.2 READ PROGRAMMED VOLTAGE COMMAND ..... 8

    2.2.3 MEASURE VOLTAGE COMMAND ..... 8

    2.2.4 PROGRAM OUTPUT CURRENT COMMAND ..... 8

    2.2.5 READ PROGRAMMED CURRENT COMMAND ..... 8

    2.2.6 MEASURE CURRENT COMMAND ..... 9

    2.2.7 ENABLE THE SUPPLY OUTPUT COMMAND ..... 9

    2.2.8 DISABLE THE SUPPLY OUTPUT COMMAND ..... 9

    2.2.9 READ OUTPUT ENABLE COMMAND ..... 9

    2.2.10 GO TO LOCAL MODE COMMAND ..... 9

    2.2.11 GO TO REMOTE MODE COMMAND ..... 10

    2.2.12 GO TO REMOTE WITH LOCAL LOCK OUT COMMAND ..... 10

    2.2.13 READ PROGRAMMING MODE COMMAND ..... 10

2.3 GLOBAL OUTPUT COMMANDS .....10

    2.3.1 USAGE ..... 10

    2.3.2 GLOBAL PROGRAM OUTPUT VOLTAGE ..... 11

    2.3.3 GLOBAL PROGRAM OUTPUT CURRENT ..... 11

    2.3.4 GLOBAL EANBLE THE SUPPLY OUTPUT COMMAND ..... 11

2.3.5	GLOBAL DISABLE THE SUPPLY OUTPUT COMMAND	11
2.3.6	GLOBAL RESET COMMAND	11
2.3.7	GLOBAL SAVE POWER SUPPLY SETTINGS COMMAND	12
2.3.8	GLOBAL RECALL POWER SUPPLY SETTINGS COMMAND	12
<b>2.4</b>	<b>OUTPUT PROTECTION COMMANDS .....</b>	<b>12</b>
2.4.1	OVER VOLTAGE PROTECTION	12
2.4.2	CURRENT FOLD BACK PROTECTION	14
<b>2.5</b>	<b>OPERATING CONDITION COMMANDS .....</b>	<b>15</b>
2.5.1	SYSTEM ERROR ENABLE COMMAND	15
2.5.2	READ SYSTEM ERROR COMMAND	15
2.5.3	READ SUPPLY OUTPUT MODE COMMAND	15
2.5.4	SET POWER SUPPLY POWER-UP MODE COMMAND	15
2.5.5	REPORT POWER SUPPLY POWER-UP MODE COMMAND	16
2.5.6	READ SCPI VERSION COMMAND	16
<b>2.6</b>	<b>COMMON COMMANDS .....</b>	<b>16</b>
2.6.1	CLEAR STATUS COMMAND	16
2.6.2	SET SERVICE REQUEST ENABLE COMMAND	16
2.6.3	READ SERVICE REQUEST ENABLE COMMAND	17
2.6.4	READ STATUS BYTE COMMAND	17
2.6.5	SET STANDARD EVENT STATUS 'ENABLE' REGISTER COMMAND	17
2.6.6	READ STANDARD EVENT STATUS 'ENABLE' REGISTER COMMAND	17
2.6.7	READ STANDARD EVENT STATUS 'EVENT' REGISTER COMMAND	18
2.6.8	READ IDENTITY COMMAND	18
2.6.9	RESET COMMAND	18
2.6.10	SELF TEST QUERY COMMAND	18
2.6.11	OPERATION COMPLETE COMMAND	19
2.6.12	READ OPERATION COMPLETE COMMAND	19
2.6.13	SAVE POWER SUPPLY SETTINGS COMMAND	19
2.6.14	RECALL POWER SUPPLY SETTINGS COMMAND	19
<b>2.7</b>	<b>INSTRUMENT SELECT COMMANDS .....</b>	<b>20</b>
2.7.1	SELECT SUPPLY	20
2.7.2	READ SELECTED SUPPLY NUMBER	20
<b>2.8</b>	<b>STATUS COMMANDS .....</b>	<b>20</b>
2.8.1	READ OPERATIONAL CONDITION 'EVENT' REGISTER COMMAND	20
2.8.2	READ OPERATIONAL CONDITION 'CONDITION' REGISTER COMMAND	21
2.8.3	SET OPERATIONAL CONDITION 'ENABLE' REGISTER COMMAND	21
2.8.4	READ OPERATIONAL CONDITION 'ENABLE' REGISTER COMMAND	21
2.8.5	READ QUESTIONABLE CONDITION 'EVENT' REGISTER COMMAND	21
2.8.6	READ QUESTIONABLE CONDITION 'CONDITION' REGISTER COMMAND	21
2.8.7	SET QUESTIONABLE CONDITION 'ENABLE' REGISTER COMMAND	22
2.8.8	READ QUESTIONABLE CONDITION 'ENABLE' REGISTER COMMAND	22
2.8.9	SET QUESTIONABLE INSTRUMENT SUMMARY 'ENABLE' REGISTER COMMAND	22
2.8.10	READ QUESTIONABLE INSTRUMENT SUMMARY 'ENABLE' REGISTER COMMAND	22
2.8.11	READ QUESTIONABLE INSTRUMENT SUMMARY 'EVENT' REGISTER COMMAND	22
2.8.12	STATUS PRESET COMMAND	22
<b>2.9</b>	<b>USING ERROR AND STATUS REGISTERS .....</b>	<b>23</b>
2.9.1	OVERVIEW: REGISTER FAN-OUT	23
2.9.2	GLOSSARY OF REGISTER TERMS	23
2.9.3	CLEAR ALL STATUS REGISTERS	24
2.9.4	SERVICE REQUESTS AND STATUS BYTE REGISTER	24
2.9.5	STANDARD EVENT STATUS 'EVENT' REGISTER	25

2.9.6	THE OPERATIONAL REGISTERS	26
2.9.7	THE QUESTIONABLE CONDITION REGISTERS	27
2.9.8	THE SUMMARY REGISTERS	28

**3. SYSTEM:ERROR MESSAGES.....29**

**List of Figures**

FIGURE 1.	MULTI DROP POWER SUPPLIES CONFIGURATION .....	2
FIGURE 2.	IEEE CONNECTOR AND IEEE SELECT SWITCH LOCATION.....	3
FIGURE 3.	IEEE SELECT SWITCH .....	3
FIGURE 4.	STATUS AND ERROR REGISTER TREE POINT-TO-POINT MODE.....	31
FIGURE 5.	STATUS AND ERROR REGISTER TREE MULTI DROP MODE.....	32
FIGURE 6.	INSTRUMENT SUMMARY REGISTER TREE MULTI DROP MODE.....	33

**List of Tables**

TABLE 1.	THE STATUS BYTE REGISTER.....	24
TABLE 2.	THE STANDARD EVENT STATUS REGISTER.....	25
TABLE 3.	THE OPERATIONAL REGISTERS .....	26
TABLE 4.	THE QUESTIONABLE REGISTERS .....	27
TABLE 5.	SYSTEM ERROR CODES .....	29
NOTES	.....	34

## **1. THE DIGITAL (IEEE 488.2 SCPI) PROGRAMMING OPTION**

### **1.1 INTRODUCTION**

The internal factory installed GPIB interface allows to operate the Genesys™ Power Supply from a computer via IEEE-488 communication bus.

The GPIB interface allows the user complete remote control of the power supply, including output voltage and current limit programming, setting the Over Voltage Protection, Under Voltage Limit and Foldback protection. The Output Voltage and Output Current can be measured and the power supply status can be monitored.

Commands that are standard with digital programming include:

- Program Voltage
- Measure Voltage
- Over-Voltage Shutdown
- IEEE-488.2 Compliant
- Program Current
- Measure Current
- Current Fold Back Shutdown
- SCPI Compliant

### **1.2 SCOPE OF MANUAL**

This manual contains the information needed to operate the optional embedded digital interface used in the Power Supply. The interface is contained on one circuit card. It is optionally installed by the factory at the time of manufacture.

### **1.3 CONFIGURATION**

To operate on the IEEE 488.2 bus, each supply will require that an IEEE Programming Interface be installed.

### **1.4 GLOSSARY**

1. The **HOST PC** will be the computer in control of the GEN supply(s) when operating under computer (Remote) control.
2. **Point-to-Point Mode** will mean that 1 IEEE Interface can control only 1 GEN supply.
3. **Multi Drop Mode** will mean that 1 IEEE Interface can control more than 1 GEN supply.
4. When in Multi Drop Mode the GEN supply with the IEEE Interface installed will be referred to as the **Master Supply** and all other attached supplies will be referred to as **Slave Supplies**.
5. A **Communication Collision** (AKA collision) is an event when in Multi Drop Mode more than 1 GEN supply attempts to transmit data simultaneously.
6. The **Main micro.** is the microprocessor installed on the GENESYS power supply control board that monitors/controls all power supply activity.
7. The **IEEE micro.** is the microprocessor installed on the IEEE Interface that is installed within the power supply.
8. **Local Mode** means that the supply under control of the “Front Panel Knob” or “Rear Panel Analog Remote” inputs.
9. **Remote Mode** means that the supply operating under direction of HOST PC/IEEE Interface via the IEEE488.2 Bus. Front panel does not operate except to view settings.
10. **Serial Interface** means that the Master supply is interfaced to the IEEE Interface via RS-232 digital communications and Slave supplies are interfaced to the IEEE Interface via RS485 daisy chain from the Master supply. This is done to activate Remote Control or to monitor supply activity while in Local Mode.
11. **Instrument Summary Bit** is a bit in an Instrument Summary Register (Ref. Figure 6 and

2.9.8.1) indicating the address of a supply that sent an SRQ.

## 1.5 USING DIGITAL PROGRAMMING

### 1.5.1 THE IEEE-488.2 INTERFACE

The IEEE-488 digital programming interface (also called the GPIB interface) is a popular way to connect instruments to a computer. It uses a specialized 24-pin cable with connectors that allow cables to be 'stacked' together. There are eight data wires; eight control wires and eight ground wires. If the system runs from a personal computer, there are numerous vendors of IEEE controller cards and software.

The IEEE-488 standard has gone through several upgrades. The IEEE-488.1 focused on the handshaking of the eight control lines. The IEEE-488.2 added status registers inside each instrument and it added common commands to make programming groups of instrument easier. The latest specification, SCPI, adds guidelines for the command syntax so one vendor's power supply will use the same commands as another's. The Interface follows all of these standards.

Because many instruments may be connected and independently controlled by a single IEEE controller, each instrument must have a unique address. The IEEE controller automatically sets its address equal to the power supply address.

### 1.6 POINT-TO-POINT MODE vs MULTI DROP MODE

Upon application of AC power to the Power Supply, the PS IEEE Interface will query the Power Supply to test if the Multi Drop installed. If the Multi Drop Option is installed, the IEEE Interface will activate the Multi-Drop mode (regardless of the number of units connected to the IEEE Interface). An example of a Multi-Drop Power Supply configuration is shown in Figure 1. . If the Multi Drop Option is not installed, the IEEE Interface will activate the Point-to-Point mode.

When more than one Power Supply is connected to a single Power Supply with IEEE Interface (in Multi-Drop mode), all of the Power Supplies must have the Multi Drop Option installed. See Figure 1 for a Multi-Drop Power Supply configuration.

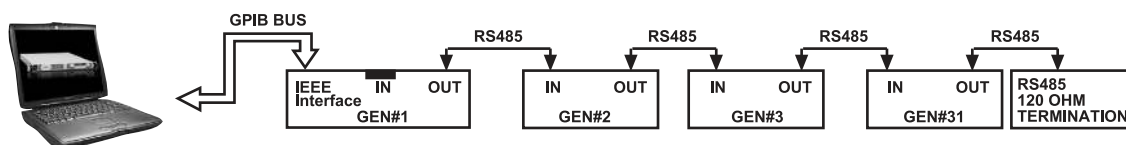

**Figure 1. Multi Drop Power supplies configuration**



## 1.7 CONFIGURING THE IEEE INTERFACE

### 1.7.1 SETTING THE POWER SUPPLY AND IEEE SELECT SWITCH

Power supply setting – set rear panel DIP switch (SW1) all contact to Down position.

The interface contains a two position DIP switch that is accessible from the rear of the Power Supply and located next to the IEEE cable connector. Switch 2, located to the right of Switch1, is not used. Refer to Figure 2 for location of the IEEE connector and the IEEE select switch at the rear panel of the supply.

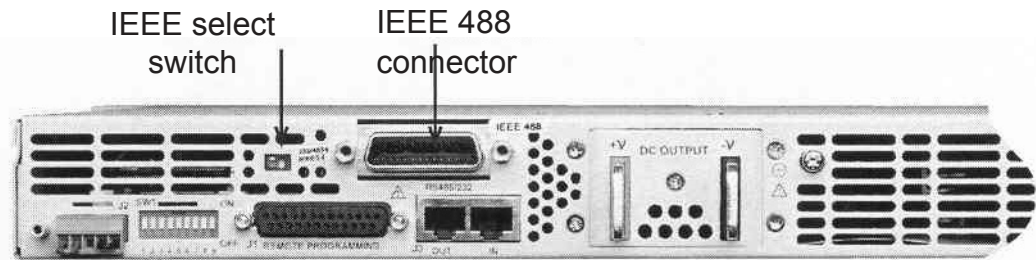

**Figure 2. IEEE Connector and IEEE Select Switch Location**

Placing Switch 1 in the ON Position, up, will activate this interface and deactivate the Power Supply's Serial I/O capability. Placing Switch 1 in the OFF Position, down, will deactivate this interface and activate the Power Supply's Serial (RS232 or RS485) I/O capability.

The position of Switch 1 may be changed at any time; but the new setting will not take affect until the power is switched off and on.

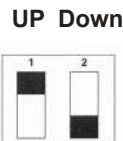

**Figure 3. IEEE Select Switch**

### 1.7.2 CONFIGURING THE IEEE CONTROLLER

A typical IEEE controller is a personal computer with an IEEE interface card. Each card vendor supplies its own configuration instructions and interface software.

Each time the software is executed, the controller must be configured as follows:

- Controller Address = 0. This is factory default for all controllers.
- EOI Flag = TRUE. The “End or Identify” is a control line in the IEEE cable that is asserted when the last character of a message string is sent. It is required for this interface.
- EOS Flag = FALSE: The “End of String”, used in some instruments to indicate the last character of a message, is not supported by this interface.

## 1.8 CONFIGURING THE SUPPLIES

No configuration is required for the Master Supply. The IEEE Interface will adapt the address of the Master Supply as its IEEE address.

Slave supplies must be given a unique address that is different than the address of the Master supply. No two supplies may be given the same address. All Slave supplies must be set for RS485 operation at 19,200 Baud transmission rate.

## 1.9 THE INTERFACE INPUT BUFFER

The Interface contains a 210 byte input buffer to save commands as they are received from the IEEE488.2 bus. The buffer is divided into fourteen 14 byte fields. Thus the command:

SOURCE:VOLTAGE:AMPLITUDE 123.45 will consume 4 fields

and the command:

:VOLTAGE 123.45 will consume 2 fields.

The user may enter more than 1 concatenated command, separated by semicolons, to be executed. The interface will process all commands before returning any data/status to the IEEE bus or accepting any new commands to execute. Messages returned to the user will be the result of the last command executed.

If a command error exists, or the Power Supply reports an error, all subsequent commands in the buffer will be terminated and the status returned to the user.

If the user enters more than 16 fields an error will be generated. Also, if the user enters more than 13 bytes in any field, an error will be generated.

## 1.10 GETTING STARTED WITH THE SOFTWARE

A computer can use a variety of controllers, programs, and programming languages for the IEEE bus. Here is an example showing a minimal program to set the voltage, set the current and measure the voltage from a power supply.

### 1.10.1 EXAMPLE SESSION USING THE 'IBIC' CONSOLE

A popular console program is National Instruments "Win32 Interactive Control" (file: ibic.exe). As the operator types each command on the computer, at the colon prompt, it is immediately sent to the power supply. This example works only for computers with National Instruments and compatible IEEE controller cards.

```
Win32 Interactive Control
```

```
Copyright 1996 National Instruments Corporation
```

```
All rights reserved.
```

```
Type 'help' for help or 'q' to quit.
```

```
: ibdev  
  enter board index: 0  
  enter primary address: 6  
  enter secondary address: 0  
  enter timeout: 12
```

Controller address

Supply Address

```
enter 'EOI on last byte' flag: 1
enter end-of-string mode/byte: 10

ud0: ibwrt "sour:volt 100"
[0100] ( cmpl )
count: 12

ud0: ibwrt "sour:curr 5"
[0100] ( cmpl )
count: 11

ud0: ibwrt "meas:volt?"
[0100] ( cmpl )
count: 10

ud0: ibrd 50
[2100] ( end cmpl )
count: 11
31 30 30 2e 30 38 0a
```

Program supply to  
100 volts output

Program supply to  
5 amps output

Query: "What is  
output voltage?"

Read response

Supply reported output voltage  
1 0 0 . 0 8 .

## 1.10.2 EXAMPLE PROGRAM WRITTEN IN VISUAL BASIC

Microsoft's Visual Basic is a windows programming language that may be used to create "virtual instruments" and automation programs. Here is a simple program which sends commands to a power supply to set the voltage, set the current and measure the voltage. The program's window only contains two items: a "Start" button and a text box to show the measured voltage. The syntax of the CALLED functions are correct only for National Instruments and compatible IEEE controllers. Don't forget to add the forms "Ni-global.bas" and "Vbib-32.bas" to your project.

### Example Program Written in Visual Basic

```
Option Explicit
Dim SupplyUD As Integer          'supply device descriptor
Dim strMeasVolt As String * 50  'buffer for reading input message

Private Declare Function GetTickCount Lib "kernel32" () As Long

Private Sub cmdStart_Click()
' start program here after "Start" button clicked
    'open IEEE port, get "User Device Description" = SupplyUD
```

```

`assume power supply address is set to "6" on DIP switch
Call ibdev(0, 6, 0, T3s, 1, 10, intSupplyUD)

Call ibwrt(SupplyUD, ":volt 100")    `program output to 100 volts
Call ibwrt(SupplyUD, ":curr 2")     `program output to 2 amps
Wait 500                             `wait 0.5 sec to settle
Call ibwrt(SupplyUD, "meas:volt?")  `ask "What is output voltage?"
Call ibrd(SupplyUD, strMeasVolt)    `read back output voltage
txtOutVolt.Text = strMeasVolt       `display output voltage on window
End Sub

Private Sub Wait(mSecWait As Long)
`subroutine to wait "mSecWait" milliseconds
Dim StartTime As Long
StartTime = GetTickCount
Do
Loop While (GetTickCount - StartTime < mSecWait)
End Sub

```

### 1.10.3 EXAMPLE PROGRAM WRITTEN IN LABVIEW

The National Instruments LabVIEW programming language is a popular language which is optimized for instrument control and data analysis. It is a graphical language where functions are shown as icons with connection points and data flows along drawn lines. Here is a simple program which sends commands to a power supply to set the voltage, set the current and measure the voltage. The program's window only contains two items: a numeric control for the supply IEEE address and a text indicator to show the measured voltage.

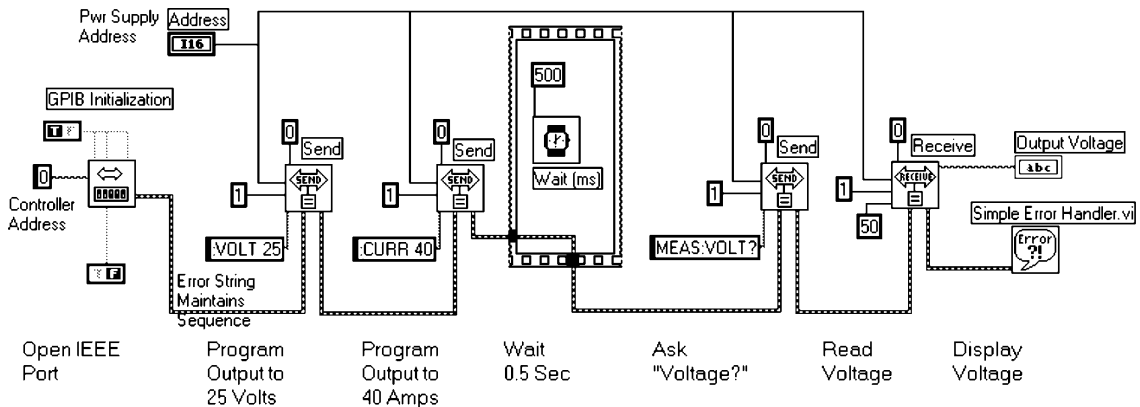

## 2. PROGRAMMING COMMANDS

### 2.1 COMMAND NOTES

Expressions enclosed in square brackets, [ ], are optional and entered without the [ or ].

Expressions enclosed in greater than/less than, < >, are programming values and entered without the < or >.

The expression <SP> represents a one character ASCII Space.

In all commands upper case characters can be interchanged with lower case characters.

WORD	CAN BE REPLACED WITH
:AMPLITUDE	:AMPL
:CONDITION	:COND
:CURRENT	:CURR
:ENABLE	:ENAB
:ERROR?	:ERR?
:EVENT	:EVEN
GLOBAL	GLOB
INSTRUMENT	INST
:IMMEDIATE	:IMM
:ISUMMARY1	:ISUM1
:ISUMMARY2	:ISUM2
:ISUMMARY3	:ISUM3
:LEVEL	:LEV
:LIMIT	:LIM
MEASURE	MEAS
MODE?	MOD?
:NSELECT	:NSEL
:OPERATION	:OPER
:OUTPUT	OUTP
:PRESET	:PRES
:PROTECTION	:PROT
:QUESTIONABLE	:QUES
:SELECT	:SEL
SOURCE	SOUR
:STATE	:STAT
STATUS	STAT
SYSTEM	SYST
:TRIPPED	:TRIP
:VERSION	:VERS
:VOLTAGE	:VOLT

### 2.2 PROGRAMMING AND MESUREMENT COMMANDS

#### 2.2.1 PROGRAM OUTPUT VOLTAGE

The output voltage can be programmed by sending the command:

[SOURce]:VOLTage[:LEVel][:IMMediate][:AMPLitude]<SP> <value>

where <value> is any valid voltage with or without a decimal place.

Alternate Format:

```
SOURCE:VOLTAGE<SP><value>
:VOLTAGE:AMPLITUDE<SP><value>
:VOLTAGE<SP><value>
```

Examples:

```
SOURCE:VOLTAGE:AMPLITUDE 15.77
:VOLTAGE 3.25
```

### **2.2.2 READ PROGRAMMED VOLTAGE COMMAND**

To read what voltage the supply was programmed to, regardless of the actual voltage, send the following command and read the response message.

```
[SOURce]:VOLTage[:AMPLitude]?
```

Alternate Format:

```
SOURCE:VOLTAGE?
:VOLTAGE:AMPLITUDE?
:VOLTAGE?
```

Examples:

```
SOURCE:VOLTAGE:AMPLITUDE?
:VOLTAGE?
```

### **2.2.3 MEASURE VOLTAGE COMMAND**

The output voltage can be measured by sending the command:

```
MEASure:VOLTage?
```

When the controller does the next IEEE Read, the interface will send the measured voltage to it.

Example:

```
MEASURE:VOLTAGE?
```

### **2.2.4 PROGRAM OUTPUT CURRENT COMMAND**

The output current is programmed by sending the command:

```
[SOURce]:CURRent[:LEVel][:IMMediate][:AMPLitude]<SP><value>
```

where < value > is any valid current with or without a decimal place.

Alternate Formats:

```
SOURCE:CURRENT<SP><value>
:CURRENT:AMPLITUDE<SP><value>
:CURRENT<SP><value>
```

Examples:

```
SOURCE:CURRENT:AMPLITUDE 15.77
:CURRENT 3.25
```

### **2.2.5 READ PROGRAMMED CURRENT COMMAND**

To read what current the supply was programmed to, regardless of the actual current, send the following command and read the response message.

```
[SOURce]:CURRent[:AMPLitude]?
```

Alternate Format:

```
SOURCE:CURRENT?
:CURRENT:AMPLITUDE?
:CURRENT?
```

Examples:

```
SOURCE:CURRENT:AMPLITUDE?
:CURRENT?
```

### **2.2.6 MEASURE CURRENT COMMAND**

The output current can be measured by sending the SCPI command:

MEASure:CURRent?

When the controller does the next IEEE Read, the supply will return the amperes of current being produced

Example:

MEASURE:CURRENT?

### **2.2.7 ENABLE THE SUPPLY OUTPUT COMMAND**

The power supply output can be turned on by sending this command:

OUTPut:STATe<SP>1

The output will immediately jump to the last programmed voltage and current.

Example:

OUTPUT:STATE 1

Notes:

1 can be replaced with ON

### **2.2.8 DISABLE THE SUPPLY OUTPUT COMMAND**

The power supply output can be shut off by sending this command:

OUTPut:STATe<SP>0

This command is equivalent to programming the output to zero volts.

Example:

OUTPUT:STATE 0

Notes:

0 can be replaced with OFF

### **2.2.9 READ OUTPUT ENABLE COMMAND**

Reads the Power Supply output enable. Places a 1 in the output queue if the supply is enabled and a 0 if the supply is disabled.

Syntax:

OUTPut:STATe?

Example:

OUTPUT:STATE?

### **2.2.10 GO TO LOCAL MODE COMMAND**

Places the supply under control of the Front Panel Controls.

Syntax:

SYSTem:SET<SP><0>

Example:

SYSTEM:SET 0

Notes:

0 can be replaced with LOC

### **2.2.11 GO TO REMOTE MODE COMMAND**

Places the supply under control of the IEEE Interface.

Syntax:

SYSTem:SET<SP><1>

Example:

SYSTEM:SET 1

Notes:

1 can be replaced with REM

### **2.2.12 GO TO REMOTE WITH LOCAL LOCK OUT COMMAND**

Places the supply under control of the IEEE Interface and disables the Front Panel Go To Local Button.

Syntax:

SYSTem:SET<SP><2>

Example:

SYSTEM:SET 2

Notes:

2 can be replaced with LLO

### **2.2.13 READ PROGRAMMING MODE COMMAND**

Reads the mode of the Power Supply. Place a 0 in the output queue if the supply is in Local Mode, a 1 if the supply is in Remote Mode and a 2 if the supply is in Remote Mode with Local Lock Out.

Syntax:

SYSTem:SET?

Example:

SYSTEM:SET?

Returns:

"LOC"

"REM"

"LLO"

## **2.3 GLOBAL OUTPUT COMMANDS**

### **2.3.1 USAGE**

- Global Commands are not SCPI compliant
- Supplies acting upon Global Commands need not be a currently addressed supply
- All supplies attached to the Interface must be capable of accepting Global Commands
- No messages, OPC or Not Busy will be returned to the HOST PC after a Global Command has been issued. The Busy Bit of the Status Byte, see Figure 1 and Figure 2, will be set to 0 after this command is issued.
- It will be the responsibility of the User Software to add a 200 Ms delay after each Global Command is issued and before any other command can be issued.



**2.3.2 GLOBAL PROGRAM OUTPUT VOLTAGE**

The output voltage of all supplies can be programmed by sending the command:

```
GLOBAL:VOLTage[:LEVel][:IMMediate][:AMPLitude]<SP> <value>
```

where <value> is any valid voltage with or without a decimal place.

Alternate Format:

none

Example:

```
GLOBAL:VOLTAGE:AMPLITUDE 15.77
```

**2.3.3 GLOBAL PROGRAM OUTPUT CURRENT**

The output current of all supplies are programmed by sending the command:

```
GLOBALCURREnt[:LEVel][:IMMediate][:AMPLitude]<SP><value>
```

where < value > is any valid current with or without a decimal place.

Alternate Formats:

none

Examples:

```
GLOBAL:CURRENT:AMPLITUDE 15.77
```

**2.3.4 GLOBAL EANBLE THE SUPPLY OUTPUT COMMAND**

All power supply outputs can be turned on by sending this command:

```
GLOBAL:OUTPut:STATe<SP>1
```

The output will immediately jump to the last programmed voltage and current.

Example:

```
GLOBAL:OUTPUT:STATE 1
```

Notes:

1 can be replaced with ON

**2.3.5 GLOBAL DISABLE THE SUPPLY OUTPUT COMMAND**

All power supply outputs can be shut off by sending this command:

```
GLOBAL:OUTPut:STATe<SP>0
```

This command is equivalent to programming the output to zero volts.

Example:

```
GLOBAL:OUTPUT:STATE 0
```

Notes:

0 can be replaced with OFF

**2.3.6 GLOBAL RESET COMMAND**

Resets all Power Supplies. Voltage and current are set to 0. Supply output is set to OFF. Supply enters Remote Mode Operation.

Syntax:

```
GLOBAL:*RST
```

Example:

```
GLOBAL:*RST
```

### **2.3.7 GLOBAL SAVE POWER SUPPLY SETTINGS COMMAND**

Sends a command to all Power Supplies causing them to save their operating settings:

Programmed voltage, Current, Over Voltage, Under Voltage, Remote/Local Mode, Auto/Safe Restart, Current Fold Back, etc. can be stored in Memory.

To change one or more settings, enter the one or more commands with new settings and then enter this command.

Syntax:

GLOBAL:\*SAV<SP><0>

Example:

GLOBAL:\*SAV 0

### **2.3.8 GLOBAL RECALL POWER SUPPLY SETTINGS COMMAND**

Sends a command to all Power Supplies causing them to recall their operating settings:

Recall Programmed voltage, Current, Over Voltage, Under Voltage, Remote/Local Mode, Auto/Safe Restart and Current Fold Back. If the output of the supply was set to an OFF condition by the Front Panel Button before the \*RCL command was sent, the supply will remain in the OFF state.

Syntax:

GLOBAL :\*RCL<SP><0>

Example:

GLOBAL :\*RCL 0

## **2.4 OUTPUT PROTECTION COMMANDS**

### **2.4.1 OVER VOLTAGE PROTECTION**

#### **2.4.1.1 SET THE OVER VOLTAGE PROTECTION LEVEL COMMAND**

Set the over voltage protection level of the Power Supply to <value>, where <value> is a number between zero and the maximum supply output voltage. A decimal point is optional.

Syntax:

[SOURce]:VOLTage:PROTection:LEVel<SP><value>

Alternate Format:

:VOLTAGE:PROTECTION:LEVEL<SP><value>

Examples:

SOURCE:VOLTAGE:PROTECTION:LEVEL 25.00

SOURCE:VOLTAGE:PROTECTION:LEVEL MAX

Notes:

If <value> equals MAX, the supply will set its over voltage to its maximum level.

**2.4.1.2 READ THE OVER VOLTAGE PROTECTION LEVEL COMMAND**

Read the over voltage protection level of the Power Supply.

Syntax:

[SOURce]:VOLTage:PROTection:LEVel?

Alternate Format

:VOLTAGE:PROTECTION:LEVEL?

Example:

SOURCE:VOLTAGE:PROTECTION:LEVEL?

**2.4.1.3 READ OVER VOLTAGE TRIPPED STATE COMMAND**

Read if the Power Supply over voltage has tripped.

Syntax:

[SOURce]:VOLTage:PROTection:TRIPped?

Alternate Format:

:VOLTAGE:PROTECTION:TRIPPED?

Example:

SOURCE:VOLTAGE:PROTECTION:TRIPPED?

Read the response number. The normal response is “0” (zero). If a “1” (one) is returned, an over voltage has occurred and the output is shut down.

**2.4.1.4 SET THE UNDER VOLTAGE PROTECTION LEVEL COMMAND**

Set the under voltage protection level of the Power Supply.

Syntax:

[SOURce]:VOLTage:LIMit:LOW<SP><value>

Alternate Format:

:VOLTAGE:LIMIT:LOW<SP><value>

Example:

SOURCE:VOLTAGE:LIMIT:LOW 25.00

**2.4.1.5 READ THE UNDER VOLTAGE PROTECTION LEVEL COMMAND**

Read the under voltage protection level of the Power Supply.

Syntax:

[SOURce]:VOLTage:LIMit:LOW?

Alternate Format

:VOLTAGE:LIMIT:LOW?

Example:

SOURCE:VOLTAGE:LIMIT:LOW?

## **2.4.2 CURRENT FOLD BACK PROTECTION**

### **2.4.2.1 SET CURRENT FOLD BACK PROTECTION COMMAND**

Turn on the current fold back protection of the Power Supply.

Syntax:

[SOURce]:CURRent:PROTection:STATe<SP><1>

Alternate Format:

:CURRENT:PROTECTION:STATE<SP>1

Example:

SOURCE:CURRENT:PROTECTION:STATE 1

### **2.4.2.2 CLEAR CURRENT FOLD BACK PROTECTION COMMAND**

Turn off the current fold back protection of the Power Supply.

Syntax:

[SOURce]:CURRent:PROTection:STATe<SP><0>

Alternate Format:

:CURRENT:PROTECTION:STATE<SP>0

Example:

SOURCE:CURRENT:PROTECTION:STATE 0

### **2.4.2.3 READ CURRENT FOLD BACK STATE COMMAND**

Read if the Fold back is enabled or disabled. The interface will return an ON if Fold Back Protection is set or an OFF if not set.

Syntax:

[SOURce]:CURRent:PROTection:STATe?

Alternate Format:

:CURRENT:PROTECTION:STATE?

Example:

SOURCE:CURRENT:PROTECTION:STATE?

### **2.4.2.4 READ FOLD BACK TRIPPED STATE COMMAND**

Read if the Power Supply Current Fold Back has tripped. The interface will return a 1 if Fold Back Protection has tripped or a 0 if not tripped.

Syntax:

[SOURce]:CURRent:PROTection:TRIPped?

Alternate Format:

:CURRENT:PROTECTION:TRIPPED?

Example:

SOURCE:CURRENT:PROTECTION:TRIPPED?

## **2.5 OPERATING CONDITION COMMANDS**

### **2.5.1 SYSTEM ERROR ENABLE COMMAND**

Clears the Error Queue and enables all error messages to be placed in the System Error Queue. Refer to Section 3 : SYSTEM:ERROR MESSAGES for details

Syntax:

SYSTem:ERRor:ENABle

Action:

Direct the interface to save error messages.

Example:

SYSTEM:ERROR:ENABLE

### **2.5.2 READ SYSTEM ERROR COMMAND**

The oldest error message is removed from the Error Queue and placed in the Output Queue. If the Error Queue was empty, a 0 is placed in the Output Queue.

Syntax:

SYSTem:ERRor?

Example:

SYSTEM:ERROR?

Returned Message Example:

-222, "Data out of range"

### **2.5.3 READ SUPPLY OUTPUT MODE COMMAND**

Read if the Power Supply is in the Constant Voltage, Constant Current or Output Off Mode. The interface will return a CV if the supply is in Constant Voltage Mode, a CC if the supply is in Constant Current Mode or an OFF if the supply output is off.

Syntax

SOURce:MODE?:

Example:

SOURCE:MODE?:

Returns:

CV

CC or

OFF

### **2.5.4 SET POWER SUPPLY POWER-UP MODE COMMAND**

Set the Power Supply for Auto-Restart or Safe-Start operation upon power up.

Syntax:

OUTPut:PON<SP><value>

where value = 0 or OFF for Safe-Start or value = 1 or ON for Auto-Restart

Examples:

OUTPUT:PON 0,

OUTPUT:PON 1

Notes:

**This command is in addition to the SCPI compliance requirements.**

### **2.5.5 REPORT POWER SUPPLY POWER-UP MODE COMMAND**

Report the Power Supply Auto-Restart or Safe-Start operation upon power up mode. The interface will return an ON if the supply is Auto-restart operation or an OFF if the supply is in Safe-Start operation

Syntax:

OUTPut:PON?

Example:

OUTPUT:PON?

Notes:

**This command is in addition to the SCPI compliance requirements.**

### **2.5.6 READ SCPI VERSION COMMAND**

Read the SCPI Compliance year that this interface adheres to.

Syntax:

SYSTem:VERSion?

Example:

SYSTEM:VERSION?

## **2.6 COMMON COMMANDS**

### **2.6.1 CLEAR STATUS COMMAND**

Clears all event registers and stored error messages.

Relays the command to the Power Supply

Syntax:

\*CLS

Example:

\*CLS

### **2.6.2 SET SERVICE REQUEST ENABLE COMMAND**

Set the Service Request Enable Register.

Syntax:

\*SRE<SP><value>

Example:

\*SRE 140

Notes:

<value> is a decimal number representing the sum of all the enabled bits. The range of <value> is 0 to 255.

### **2.6.3 READ SERVICE REQUEST ENABLE COMMAND**

Read the value of the Service Request Enable Register.

Syntax:  
\*SRE?

Example:  
\*SRE?

Notes:

The returned <value> is a decimal number representing the sum of all the enabled bits. The range of <value> is 0 to 255.

### **2.6.4 READ STATUS BYTE COMMAND**

Read the value of the Status Register.

The Status Byte Register contains eight bits which are set to show that some other register has recorded an event or an error. See Table 1.

The response to this query will be a binary weighted number from 0 to 255.

Syntax:  
\*STB?

Example:  
\*STB?

Notes:

The returned <value> is a decimal number representing the sum of all the bits. The range of <value> is 0 to 255.

### **2.6.5 SET STANDARD EVENT STATUS 'ENABLE' REGISTER COMMAND**

Set Event Status Enable Register to a value. See Table 2 .

Syntax:  
\*ESE<SP><value>

Example:  
\*ESE 74

Notes:

<value> is a decimal number representing the sum of all the enabled bits. The range of <value> is 0 to 255.

### **2.6.6 READ STANDARD EVENT STATUS 'ENABLE' REGISTER COMMAND**

Read the value of the Event Status Enable Register. See Table 2.

Syntax:  
\*ESE?

Example:  
\*ESE?

Notes:

The returned <value> is a decimal number representing the sum of all the enabled bits. The range of <value> is 0 to 255.

### **2.6.7 READ STANDARD EVENT STATUS 'EVENT' REGISTER COMMAND**

Read the value of the Event Status Register. See Table 2 Figure 4 Figure 5 and Figure 6.

Syntax:

\*ESR?

Example:

\*ESR?

Notes:

The returned <value> is a decimal number representing the sum of all the enabled bits. The range of <value> is 0 to 16,767.

### **2.6.8 READ IDENTITY COMMAND**

Read Company Logo, Power Supply range, Serial Number and Revision of the Power Supply and Version of this IEEE Interface.

When the controller reads the output from the power supply, a single-line identity string will be returned. A typical identity string format is:

Manufacturer/Model <max volt>-<max curr>, S/N <supply serial>, REV <power supply revision-IEEE interface version>

Syntax:

\*IDN?

Example:

\*IDN?

Return message example:

Lambda, 6-200, S/N 11111-111111, REV:1U:3.0-D

### **2.6.9 RESET COMMAND**

Resets the Power Supply. Voltage and current are set to 0. Supply output is set to OFF. Supply enters Remote Mode Operation.

Syntax:

\*RST

Example:

\*RST

### **2.6.10 SELF TEST QUERY COMMAND**

Test that the Interface and the Power Supply are operational. This will be accomplished by sending a measure voltage command to the power supply. The result of the measure voltage command is ignored. The result will be tested for completion and/or error.

Syntax:

\*TST?

Example:

\*TST?

Return message example:

"0" if supply test pass

"1" if supply test fail



### **2.6.11 OPERATION COMPLETE COMMAND**

Set the Operation Complete Bit in the Standard Event Status Register when all operations have finished

Syntax:

\*OPC

Example:

\*OPC

### **2.6.12 READ OPERATION COMPLETE COMMAND**

Place a 1 in the Output Queue when all operations have finished.

Syntax:

\*OPC?

Example:

\*OPC?

### **2.6.13 SAVE POWER SUPPLY SETTINGS COMMAND**

Sends a command to the Power Supply causing it to save its operating settings:

Programmed voltage, Current, Over Voltage, Under Voltage, Remote/Local Mode, Auto/Safe Restart, Current Fold Back, etc. can be stored in Memory.

To change one or more settings, enter the one or more commands with new settings and then enter this command.

Syntax:

\*SAV<SP><0>

Example:

\*SAV 0

### **2.6.14 RECALL POWER SUPPLY SETTINGS COMMAND**

Sends a command to the Power Supply causing it to recall its operating settings:

Recall Programmed voltage, Current, Over Voltage, Under Voltage, Remote/Local Mode, Auto/Safe Restart and Current Fold Back. If the output of the supply was set to an OFF condition by the Front Panel Button before the \*RCL command was sent, the supply will remain in the OFF state.

Syntax:

\*RCL<SP><0>

Example:

\*RCL 0

## **2.7 INSTRUMENT SELECT COMMANDS**

### **2.7.1 SELECT SUPPLY**

Commands Interface to conduct communications with a designated supply when in Multi Drop Mode.

Syntax:

INSTRument:NSElect<SP><nn>                    where nn is the address of the selected supply

Example:

INSTRUMENT:SELECT 17

Notes:

Upon power up the Master Supply will be automatically selected.

:NSElect may be replaced with :SElect

### **2.7.2 READ SELECTED SUPPLY NUMBER**

Syntax:

INSTRument:NSElect?

Notes:

Returns the selected .Supply number 'xx'

## **2.8 STATUS COMMANDS**

### **2.8.1 READ OPERATIONAL CONDITION 'EVENT' REGISTER COMMAND**

Reads the Operational Condition Event Register and puts the result in the Output Queue.

Syntax:

STATus:OPERation[:EVENT]?

Alternate Format:

STATUS:OPERATION?

Example:

STATUS:OPERATION:EVENT?

Notes:

The returned <value> is a decimal number representing the sum of all the event bits.

The range of <value> is 0 to 255.

### **2.8.2 READ OPERATIONAL CONDITION 'CONDITION' REGISTER COMMAND**

Reads the Operational Condition Register and puts the result in the Output Queue.

Syntax:

STATus:OPERation:CONDition?

Example:

STATUS:OPERATION:CONDITION?

Notes:

The returned <value> is a decimal number representing the sum of all the condition bits.  
The range of <value> is 0 to 255.

## 2.8.3 SET OPERATIONAL CONDITION 'ENABLE' REGISTER COMMAND

Sets the Operational Condition Enable Register.

Syntax:

STATUS:OPERation:ENABLE<SP><value>

Example:

STATUS:OPERATION:ENABLE 53

Notes:

The <value> is a decimal number representing the sum of all the enabled bits.  
The range of <value> is 0 to 255.

## 2.8.4 READ OPERATIONAL CONDITION 'ENABLE' REGISTER COMMAND

Reads the Operational Condition Enable Register.

Syntax:

STATUS:OPERation:ENABLE?

Example:

STATUS:OPERATION:ENABLE?

Notes:

The returned <value> is a decimal number representing the sum of all the enabled bits.  
The range of <value> is 0 to 255.

## 2.8.5 READ QUESTIONABLE CONDITION 'EVENT' REGISTER COMMAND

Reads the Questionable Condition Event Register and puts the result in the Output Queue.

Syntax:

STATUS:QUEStionable [:EVENT{]}?

Alternate Format:

STATUS:QUESTIONABLE?

Example:

STATUS:QUESTIONABLE:EVENT?

Notes:

The returned <value> is a decimal number representing the sum of all the event bits.  
The range of <value> is 0 to 4,095.

## 2.8.6 READ QUESTIONABLE CONDITION 'CONDITION' REGISTER COMMAND

Reads the Questionable Condition Register and puts the result in the Output Queue.

Syntax:

STATUS:QUEStionable:CONDition?

Example:

STATUS:QUESTIONABLE:CONDITION?

The returned <value> is a decimal number representing the sum of all the event bits.

The range of <value> is 0 to 4,095.

### **2.8.7 SET QUESTIONABLE CONDITION 'ENABLE' REGISTER COMMAND**

Sets the Questionable Condition Enable Register.

Syntax:

STATus:QUESTionable:ENABle<SP><value>

Example:

STATUS:QUESTIONABLE:ENABLE 53

Notes:

The <value> is a decimal number representing the sum of all the enabled bits.

The range of <value> is 0 to 4,095.

### **2.8.8 READ QUESTIONABLE CONDITION 'ENABLE' REGISTER COMMAND**

Reads the Questionable Condition Enable Register.

Syntax:

STATus:QUESTionable:ENABle?

Example:

STATUS:QUESTIONABLE:ENABLE?

The returned <value> is a decimal number representing the sum of all the event bits.

The range of <value> is 0 to 4,095.

### **2.8.9 SET QUESTIONABLE INSTRUMENT SUMMARY 'ENABLE' REGISTER COMMAND**

See Figure 6 and Section 2.9.8, THE SUMMARY REGISTERS. Enable an SRQ from a supply to set Bit 0 of the Questionable Condition 'condition' register.

Syntax:

STATus:QUESTionable:INSTrument:ISUMmary1:ENABle<SP><value> or

STATus:QUESTionable:INSTrument:ISUMmary2:ENABle<SP><value> or

STATus:QUESTionable:INSTrument:ISUMmary3:ENABle<SP><value>

Example:

STAT:QUES:INST:ISUM1:ENAB 122

Action: Enable supplies #0, 2, 3, 4 and 5 to set bit 0 of the Questionable Condition 'condition' register.

### **2.8.10 READ QUESTIONABLE INSTRUMENT SUMMARY 'ENABLE' REGISTER COMMAND**

See Figure 6 and Section 2.9.8, THE SUMMARY REGISTERS. Read which supplies can set Bit 0 of the Questionable Condition 'condition' register by sending an SRQ.

Syntax:

STATus:QUESTionable:INSTrument:ISUMmary1:ENABle? or

STATus:QUESTionable:INSTrument:ISUMmary2:ENABle? or

STATus:QUESTionable:INSTrument:ISUMmary3:ENABle?

Example:

STAT:QUES:INST:ISUM1:ENAB?

**2.8.11 READ QUESTIONABLE INSTRUMENT SUMMARY 'EVENT' REGISTER COMMAND**

See Figure 6 and Section 2.9.8, THE SUMMARY REGISTERS. Read which supplies sent an SRQ. These bits are set regardless of the value of the enable bit. When set they remain set until read.

Syntax:

STATus:QUEStionable:INSTrument:ISUMmary1? or

STATus:QUEStionable:INSTrument:ISUMmary2? or

STATus:QUEStionable:INSTrument:ISUMmary3?

Example:

STAT:QUES:INST:ISUM1?

**2.8.12 STATUS PRESET COMMAND**

Presets all Operation Enable and Questionable Enable Registers.

Syntax:

STATus:PRESet

Example:

STATUS:PRESET

**2.9 USING ERROR AND STATUS REGISTERS****2.9.1 OVERVIEW: REGISTER FAN-OUT**

The IEEE Interface board has a set of status and error registers. They are defined by the IEEE-488.2 specification as part of the IEEE 488.2 Common Command set required by all compliant instruments.

These registers allow the IEEE controller to examine the operational state of the supply in detail. A "fan-out" architecture is used so only one summary register needs to be read to know if an event occurred in any other register. This fan-out allows automatic test programs to efficiently manage the remote programming mode.

A diagram of the register structure is shown in Figure 4 for Point-to-Point Mode and in Figure 5 and Figure 6 for Multi Drop Mode.

**2.9.2 GLOSSARY OF REGISTER TERMS**

- SERVICE REQUEST: When an instrument on the IEEE bus asserts the SRQ line in the cable, it tells the controller that it has completed its task or that an error has occurred.
- SERIAL POLL: An IEEE function which reads back the data in an instrument's Status Byte Register. The controller should perform this function after every command to verify the command was successful.
- REGISTER QUERIES: Read the contents of registers. The contents are returned as a binary weighted decimal number.
- CONDITIONAL REGISTERS. These contain bits that are set when a condition or error occurs. The bits are only cleared when the condition or error is cleared. The contents may be read but not changed.
- ENABLE REGISTERS: The various Enable Registers can be set to allow the status and errors to be detectable by a Serial Poll.

- **EVENT REGISTERS:** These contain bits that are set when an event or error occurs. The bits are cleared when the contents of the register are queried.

### 2.9.3 CLEAR ALL STATUS REGISTERS

\*CLS

This command clears all event registers and stored error messages. It will not affect the Conditional, Instrument Summary or the Enable registers.

### 2.9.4 SERVICE REQUESTS AND STATUS BYTE REGISTER

The Status Byte Register contains the bits that are set when an event occurs in:

Questionable Condition Event Register,

Operational Condition Event Register,

Standard Event Status Register,

or when

a message is available in the Output Queue

or when

an Error Message is available in the Error Queue.

If any of these bits are set, and the corresponding bit is set in the Service Request Enable Register the Service Request Bite (SRQ) bit will become set.

The SRQ bit will assert a signal onto the Service Request (SRQ) line in the IEEE cable. The controller program can detect the SRQ, read what the problem is from the power supply, and clear the SRQ.

The bit assignments for the Status Byte Register are:

BIT NUMBER	DECIMAL VALUE	BIT SYMBOL	DESCRIPTION
0	1	BSY	1 = Busy, 0 = Ready
1	2	0	Not Used
2	4	SYS	System Error, Message Available in Error Que.
3	8	QUE	Questionable Summary
4	16	MAV	Message Available in Output Que. Set after query message is received
5	32	ESB	Standard Event Summary
6	64	RQS	Request For Service. Is set if SYS, QUE, MAV, ESB and/or OPR is enabled and set.
7	128	OPR	Operational Summary

**Table 1.**

**The Status Byte Register**

#### 2.9.4.1 THE SERVICE REQUEST ENABLE REGISTER

See the SET SERVICE REQUEST ENABLE COMMAND (\*SRE). With two exceptions, the Service Request Enable Register is a mirror of the Status Byte Register. Bit 0 (Busy) and Bit 6 (SRQ) will be ignored. Also note that Bits 1 is not used in this interface and will have no effect.

To enable a Service Request, the user should refer to Table 1 and determine which events need to

be enabled to cause the request, add up the decimal value for those events and supply that value to the \*SRE command.

The power up value of the Service Request Enable Register is zero, which means no Service Requests are Enabled.

### 2.9.5 STANDARD EVENT STATUS 'EVENT' REGISTER

See the READ STANDARD EVENT STATUS 'EVENT' REGISTER COMMAND (\*ESR?). The Standard Event Status Register has seven bits that indicate status and errors for the power supply and the interface.

The response message will be a binary weighted number from 0 to 255. Zero is returned if there are no errors or events. The contents of the Standard Event Status Register will be cleared to zeroes after the \*ESR? Command is executed.

The bit assignments for this register are:

BIT NUMBER	DECIMAL VALUE	BIT SYMBOL	DESCRIPTION
0	1	OPC	Operation complete
1	2	0	Not used.
2	4	QYE	Query Error
3	8	DDE	Device Dependant Error, Fault Shutdown
4	16	EXE	Execution Error
5	32	CME	Command Error
6	64	0	Not used
7	128	PON	Power On. Set when power is switched on.

**Table 2. The Standard Event Status Register**

#### 2.9.5.1 THE STANDARD EVENT STATUS 'ENABLE' REGISTER

See the SET STANDARD EVENT STATUS 'ENABLE' REGISTER COMMAND (\*ESE).

The STANDARD EVENT STATUS 'ENABLE' REGISTER is a mirror of the STANDARD EVENT STATUS 'EVENT' REGISTER.

If any bit is set in the Standard Event Status Event Register and enabled in the Standard Event Status Enable Register, the event will propagate to the Status Byte Register as a Standard Event Summary. By writing a binary weighted value to the Standard Event Status Enable Register, the bits in the Standard Event Status Event Register may be individually enabled so only selected events will cause a service request.

The power-up default is all zeroes in the enable register. This means no status or errors will be sent to the Status Byte Register. However, even if no bits are enabled, the contents of the Standard Event Status Register may always be read with the \*ESR? query.

The contents of the Standard Event Enable Register may be read by sending:

\*ESE?

The response will be a bit weighted number whose bits correspond to Table 2

## 2.9.6 THE OPERATIONAL REGISTERS

The Operational Registers are three 16-bit registers whose bits are not defined by the IEEE specification but are specific to the IEEE device.

The bit assignments for the Operational Registers are:

BIT NUMBER	DECIMAL VALUE	BIT SYMBOL	DESCRIPTION
0	1	CV	Set high if Constant Voltage Operation
1	2	CC	Set high if Constant Current Operation
2	4	NFLT	No fault
3	8	0	Not used
4	16	AST	Auto Start Enabled
5	64	FBE	Foldback Enabled
6	64	0	Not Used
7	128	LOC	Remote/Local Mode
8 to 15	N/A	0	Not used

**Table 3. The Operational Registers**

### 2.9.6.1 THE OPERATIONAL CONDITION 'CONDITION' REGISTER

See the READ OPERATIONAL CONDITION 'CONDITION' REGISTER COMMAND (STATUS:OPERATION:CONDITION?) and Table 3. The bits, as listed in Table 3 reflect the conditions under which the power supply is operating.

### 2.9.6.2 THE OPERATIONAL CONDITION 'ENABLE' REGISTER

See the READ OPERATIONAL CONDITION 'ENABLE' REGISTER COMMAND (STATUS:OPERATION:ENABLE?),

the SET OPERATIONAL CONDITION 'ENABLE' REGISTER COMMAND (STATUS:OPERATION:ENABLE) and Table 3.

The OPERATIONAL CONDITION 'ENABLE' REGISTER is a mirror of the OPERATIONAL CONDITION 'CONDITION' REGISTER.

If any bit is set in the Operational Condition 'Condition' Register and enabled in this register, the condition will propagate to the Operational Condition 'Event' Register as an event.

### 2.9.6.3 THE OPERATIONAL CONDITION 'EVENT' REGISTER

See the READ OPERATIONAL CONDITION 'EVENT' REGISTER COMMAND (STATUS:OPERATION:EVENT?) and Table 3.

The OPERATIONAL CONDITION 'EVENT' REGISTER is a mirror of the OPERATIONAL CONDITION 'CONDITION' REGISTER.

If any event is set in this Register, it will propagate to the Status Byte Register as an Operational Summary event.



**2.9.7 THE QUESTIONABLE CONDITION REGISTERS**

The Questionable Condition Registers are three 16-bit registers whose bits are not defined by the IEEE specification but are specific to the IEEE device.

The bit assignments for the Questionable Condition Registers are:

BIT NUMBER	DECIMAL VALUE	BIT SYMBOL	DESCRIPTION
0	1	0	Not used in Point-to-Point Mode Instrument Summary in Multi Drop Mode
1	2	AC	AC Fail
2	4	OTP	Over Temperature
3	8	FLD	Fold Back Protect
4	16	OVP	Over Voltage Protection
5	32	SO	Shut Off
6	64	OFF	Output Off
7	128	ENA	Output Enable
8	256	INPO	Internal Input Overflow *
9	512	INTO	Internal Overflow *
10	1024	ITMO	Internal Time Out *
11	2048	ICOM	Internal Comm Error *
12 to 15	N/A	0	Not used

**Table 4. The Questionable Registers**

\*: Event registers, reading will clear the event bit.

**2.9.7.1 THE QUESTIONABLE CONDITION ‘CONDITION’ REGISTER**

See the READ QUESTIONABLE CONDITION ‘CONDITION’ REGISTER COMMAND (STATUS: QUESTIONABLE:CONDITION?) and Table 4. The bits, as listed in Table 4 reflect the questionable error conditions under which the power supply is operating.

**2.9.7.2 THE QUESTIONABLE CONDITION ‘ENABLE’ REGISTER**

See the READ QUESTIONABLE CONDITION ‘ENABLE’ REGISTER COMMAND (STATUS: QUESTIONABLE:ENABLE?),

the SET QUESTIONABLE CONDITION ‘ENABLE’ REGISTER COMMAND (STATUS: QUESTIONABLE:ENABLE) and Table 4.

The QUESTIONABLE CONDITION ‘ENABLE’ REGISTER is a mirror of the QUESTIONABLE CONDITION ‘CONDITION’ REGISTER.

If any bit is set in the Questionable Condition ‘Condition’ Register and enabled in this register, the condition will propagate to the Questionable Condition ‘Event’ Register as an event.

**2.9.7.3 THE QUESTIONABLE CONDITION ‘EVENT’ REGISTER**

See the QUESTIONABLE CONDITION ‘EVENT’ REGISTER COMMAND (STATUS: QUESTIONABLE:EVENT?) and Table 4. The QUESTIONABLE CONDITION ‘EVENT’ REGISTER is a mirror of the QUESTIONABLE CONDITION ‘CONDITION’ REGISTER. If any event is set in this Register, it will propagate to the Status Byte Register as a Questionable Summary event.

## **2.9.8 THE SUMMARY REGISTERS**

### **2.9.8.1 INSTRUMENT SUMMARY 1/2/3**

The INSTRUMENT SUMMARY EVENT REGISTER, ISUM1 through ISUM3 (see Figure 6), will record the address of the supply causing an SRQ. These are 'EVENT' registers and the bits will remain set until read by the STAT:QUES:INST:ISUMn command. They are always enabled.

### 3. SYSTEM:ERROR MESSAGES

The Status and Error Registers described in the previous section is only one of the status methods in the IEEE board. There is also a SCPI requirement for error messages that are in the form of:

<Error Number><Comma><Quote><Error Description><Quote>

The user sends the “SYST:ERR?” query to read the error message. The messages are stored in a first-in/first-out queue.

The SYST:ERR queue can buffer up to TEN error messages, although the tenth is replaced by the –350, “Queue Overflow” if an eleventh message is generated. After the queue overflow, only the first ten messages are stored and the later messages are lost.

The SYST:ERR queue is cleared by:

- A. Reading the messages one at a time using “SYST:ERR?” until 0, “No error” is read.
- B. The \*CLS (Clear Status) command.
- C. Sending SYSTEM:ERROR:ENABLE command.

If any message is in the SYST:ERR queue (except “No error”), then bit 2 of the Status Byte is set. A Service Request is generated if enabled.

ERROR #	ERROR DESCRIPTION	ERROR EVENT	ERROR EXAMPLE
0	“No error”	No error reported	
-100	“Command error”	IEEE receives command with unspecified error	
-101	“Invalid Character”	A character was received that is <i>not</i> : a-z, A-Z, 0-9, ?, *, ., ;, period, space, CR, LF	V%LT 50 VOLT, 50
-102	“Syntax error”	IEEE receives unrecognized command word	BEAS:VOLT? VOLTS 150
-104	“Data type error”	IEEE receives command parameter with wrong type of data. Example: receives letter where number expected.	CURRENT NA OUTPUT DC
-109	“Missing parameter”	Valid command received but not enough parameters.	VOLT
-112	“Program word too long”	Command word had more than 14 characters before separator (space or colon) was found	MEASUREVOLTAGE?
-222	“Data out of range”	Attempt to program voltage, current or OVP beyond supply limits	
-241	“Hardware Missing”	When operating in Multi Drop mode, an attempt was made to address a non-existent supply.	
-350	“Queue Overflow”	Too many SYST:ERR messages are stored in this queue and the newest messages are discarded. The Max. number of stored messages is 10.	
+300	“Execution error”	General execution error.	
+301	“PV above OVP”	Attempt to program voltage above OVP setting.	
+302	“PV below UVL”	Attempt to program voltage below UVL setting.	
+304	“OVP below PV”	Attempt to set OVP below voltage setting.	
+306	“UVL above PV”	Attempt to set UVL above voltage setting.	
+307	“On during fault”	Attempt to set supply output “ON” when a fault exists	
+320	“Fault shutdown”	General message for non-specified shutdown	
+321	“AC fault shutdown”	Brown-out or phase-loss shutdown occurred	

+322	"Over-Temperature shutdown"	Over-temperature shutdown occurred	
+323	"Fold-Back shutdown"	Fold-Back shutdown occurred	
+324	"Over-Voltage shutdown"	Over-Voltage shutdown occurred	
+325	"Analog shut-off shutdown"	Shut-Off occurred from rear panel J1	
+326	"Output-Off shutdown"	Output-Off occurred from front panel button	
+327	"Enable Open shutdown"	Enable Open occurred from rear panel J1	
+340	"Internal message fault"	General non-specified Internal message fault	
+341	"Input overflow"	IEEE receive data buffer is too full.	
+342	"Internal overflow"	Serial receive buffer in IEEE is full because Supply micro sent too many characters	
+343	"Internal timeout"	IEEE did not receive response from supply before timeout period	
+344	Internal checksum	IEEE received checksum error, from supply	
+345	"Internal checksum error"	IEEE detected checksum error in message from supply	
+399	"Unknown Error"	No known error	

**Table 5. System Error Codes**

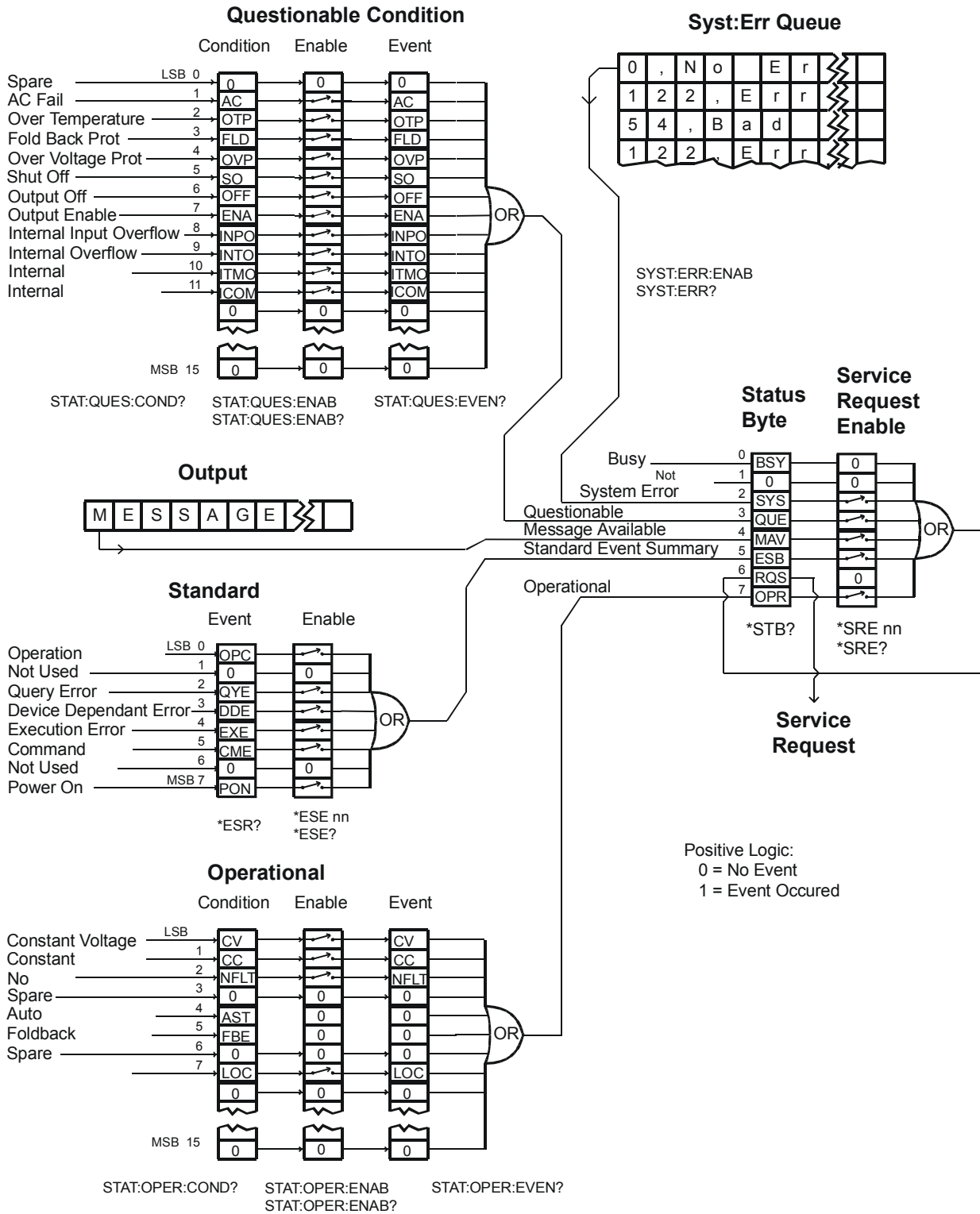

Figure 4. Status and Error Register Tree Point-to-Point Mode

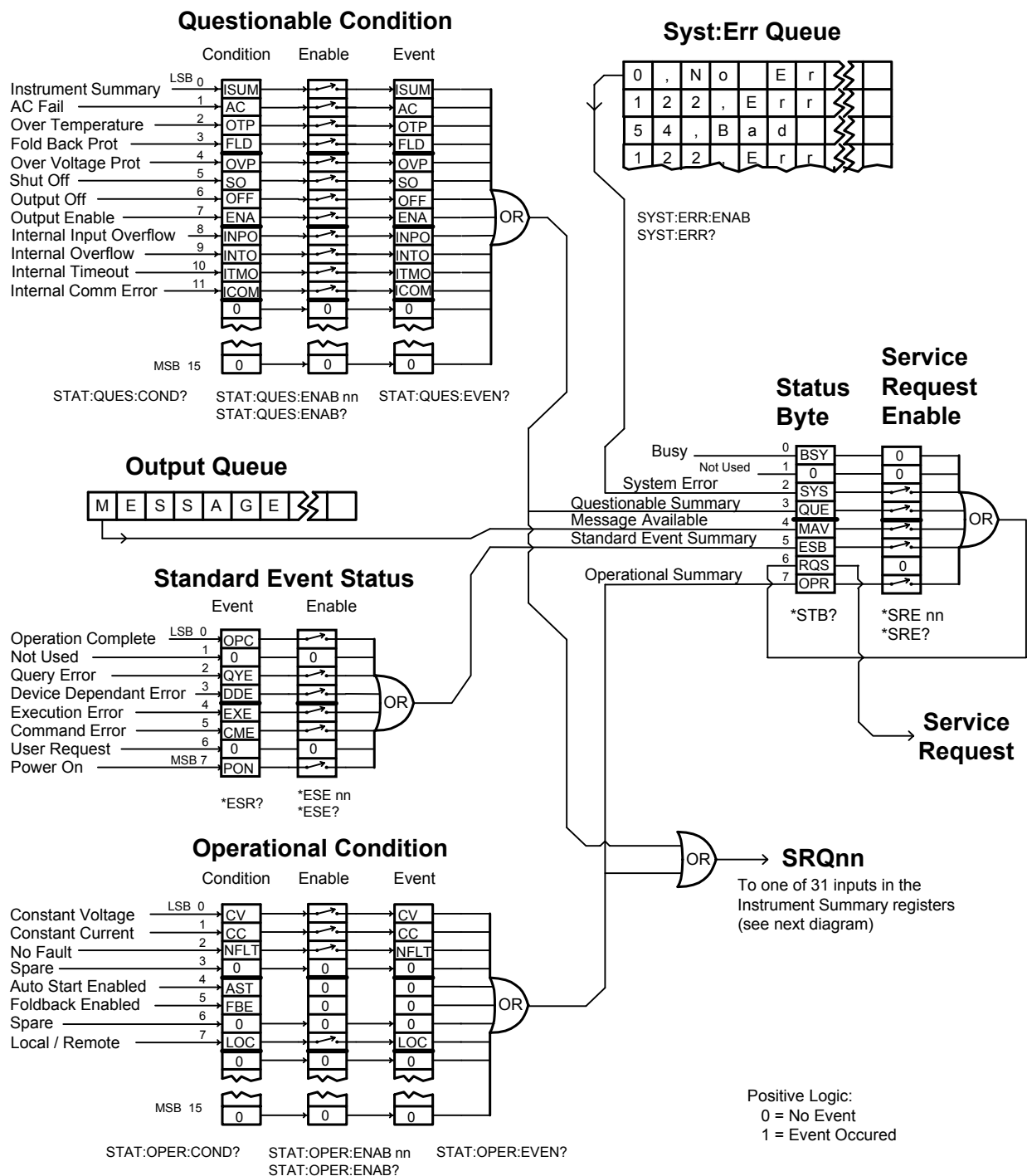

Figure 5. Status and Error Register Tree Multi Drop Mode

### Instrument Summary Registers

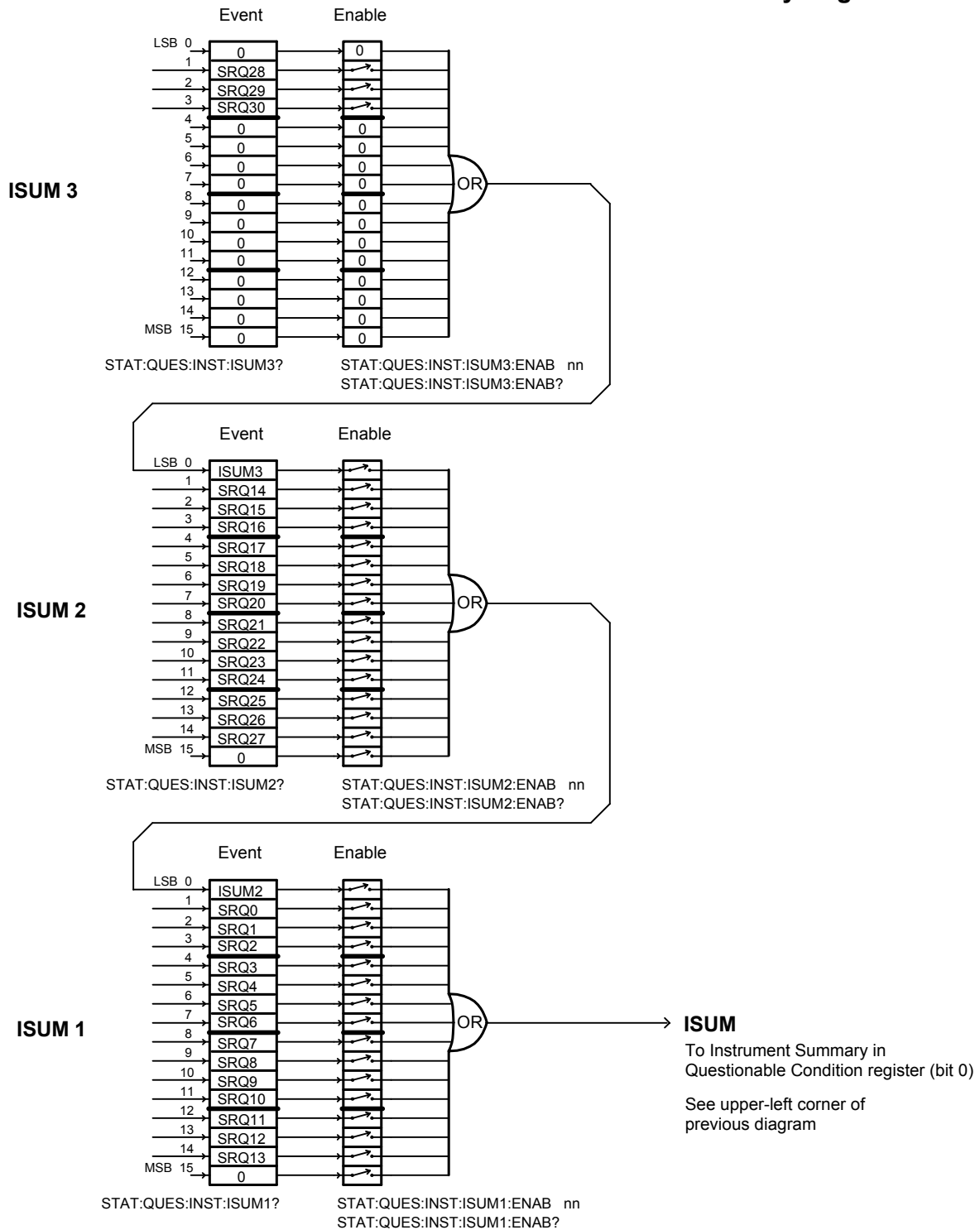

Figure 6. Instrument Summary Register Tree Multi Drop Mode





**NOTES**

---

---

---

---

---

---

---

---

---

---

---

---

---

---

---

---

---

---

---

---

---

---

---

---

---

---

---

---

---

## NORTH AMERICA

TDK-Lambda Americas Inc  
405 Essex Rd. Neptune, NJ 07753  
Tel: +1-732-922-9300 Fax: +1-732-922-1441  
E-mail: sales@us.tdk-lambda.com  
www.us.tdk-lambda.com/hp

## UK

TDK-Lambda UK Ltd.  
Kingsley Avenue Ilfracombe, Devon  
EX 34 8ES United Kingdom  
Tel: +44-1271-856666 Fax: +44-1271-864894  
E-mail: powersolutions@uk.tdk-lambda.com  
www.uk.tdk-lambda.com

## FRANCE

TDK-Lambda France SAS  
ZAC des Delaches  
BP 1077 - Gometz le Chatel  
91940 LES ULIS  
Tel: +33 1 60 12 71 65  
Fax: +33 1 60 12 71 66  
E-mail: france@fr.tdk-lambda.com  
www.fr.tdk-lambda.com

## GERMANY

TDK-Lambda Germany GmbH  
Karl-Bold-Str.40,  
D-77855 Achern, Germany  
Tel: +49-7841-666-0 Fax: +49-7841-500-0  
E-mail: info.germany@de.tdk-lambda.com  
www.de.tdk-lambda.com

## AUSTRIA

TDK-Lambda Austria Sales Office  
Aredstrasse 22,  
A - 2544 Leobersdorf, Austria  
Tel: +43-2256-65584 Fax: +43-2256-64512  
E-mail: info.germany@de.tdk-lambda.com  
www.de.tdk-lambda.com

## ITALY

TDK-Lambda Italy Sales Office  
Via dei Lavoratori 128/130  
IT20092 Cinisello Balsamo, Milano, Italy  
Tel: +39-02-6129-3863 Fax: +39-02-6129-0900  
E-mail: info.italia@it.tdk-lambda.com  
www.it.tdk-lambda.com

## ISRAEL

TDK-Lambda Ltd.  
Sales Office: Kibbutz Givat Hashlosha Tel-Aviv 4880000, Israel  
Tel: +972-3-9024-333 Fax: +972-3-9024-777  
Plant: 56 Haharoshet St.,  
Karmiel Industrial Zone 2165158, Israel  
Tel: +972-4-9887-491 Fax: +972-4-9583-071  
www.tdk-lambda.co.il E-mail: info@tdk-lambda.co.il

## JAPAN

TDK-Lambda Corporation  
International Sales Division  
Nittetsu Bldg. 6F, 1-13-1 Nihonbashi, Chuo-ku, Tokyo 103-0027, Japan  
Tel: +81-3-5201-7175  
Fax: +81-3-5201-7287  
www.tdk-lambda.com

## CHINA

Shanghai Branch of Wuxi TDK-Lambda Electronic Co. Ltd.  
28F, Xingyuan Technology Building No.418, Guiping Road,  
Shanghai, China 200233  
Tel: +86-21-6485-0777 Fax: +86-21-6485-0666  
www.cn.tdk-lambda.com

Beijing Branch of Wuxi TDK-Lambda Electronic Co. Ltd.  
Room 12B11-12B12, Unit 7 DACHENG SQUARE, No.28  
Xuanwumenxi Street, Xuanwu District Beijing, 100053, CHINA  
Tel: +86-10-6310-4872 Fax: +86-10-6310-4874  
www.cn.tdk-lambda.com

Shenzhen Branch of Wuxi TDK-Lambda Electronics Co.Ltd.  
Room 4302, Excellence Times Square Building,  
4068 Yi Tian Road, Futian District,  
Shenzhen, China 518048  
Tel: +86 -755-83588261 Fax: +86 -755-83588260  
www.cn.tdk-lambda.com

## KOREA

TDK-Lambda Corporation Seoul Office  
8F Songnam Bldg, 1358-6, Seocho-Dong,  
Seocho-Gu, Seoul, 137-862 KOREA  
Tel: +82-2-3473-7051  
Fax: +82-2-3472-9137  
www.tdk-lambda.co.kr

## SINGAPORE

TDK-Lambda Singapore Pte.Ltd.  
Blk 1008 Toa Payoh North # 07-01/03  
Singapore 318996  
Tel: +65-6251-7211 Fax: +65-6250-9171  
www.tdk-lambda.com.sg

## INDIA

TDK-Lambda Bangalore Office  
#526, Ground Floor, 10th Main, 7th Cross,  
Jeevanbhimanagar, Bangalore 560 075  
Karnataka, India  
Tel: +91-80-43550 550  
Fax: +91-80-43550 501  
www.tdk-lambda.com.sg

## MALAYSIA

TDK-Lambda Malaysia Sdn. Bhd.  
c/o TDK (Malaysia) Sdn Bhd  
Lot 709, Nilai Industrial Estate 71800 Nilai  
Negeri Sembilan, Malaysia  
Tel: + 60 6-799 1130  
Fax: + 60 6 799 3277  
www.tdk-lambda.com.my



TDK-Lambda EMEA  
www.emea.tdk-lambda.com