

Increasing the Life of Electrolytic Capacitor Banks Using Integrated High Performance Film Capacitors

M. A. Brubaker, D. El Hage, T. A. Hosking, H. C. Kirbie, and E. D. Sawyer
SBE, Inc. 81 Parker Road, Barre, VT 05641, USA
Email: info@sbelectronics.com

Abstract

Inverters for wind and solar applications require DC link capacitors to provide a local reservoir of charge during switching, and store energy for ride-through of grid events. Electrolytic capacitors are desirable for this application with regard to capacitance density, but must be de-rated for acceptable service life. A hybrid bank combining the best features of film and electrolytic capacitors has been developed to address this problem. Advanced film capacitors supply the high frequency components of the system ripple current to reduce electrolytic temperature rise and increase life. Simulation and laboratory test results are presented for practical DC link capacitor banks.

1. Introduction

The voltage source inverter is a common element of power electronics for both wind and solar energy applications. Such inverters inevitably require a DC link capacitor [1] between the DC source and the IGBT half-bridges. This capacitor provides a local supply of charge to support switching events and in many cases must store sufficient energy to allow the inverter to react to grid events (e.g. ride-through). Two capacitor technologies are available to support this function, namely film and electrolytic, which offer dramatically different performance attributes. Film offers high current rating with relatively low capacitance density, while electrolytic is the exact opposite with excellent capacitance density and low current capability. Traditionally, electrolytic banks are used to achieve high DC link capacitance, but the capacitors must be significantly de-rated to achieve a long service life.

A novel approach using a hybrid film/electrolytic bank has been developed to address this problem. The design incorporates high performance annular form factor film capacitors [2] inserted between the IGBTs and conventional electrolytic bank. When properly implemented, this approach allows the film capacitors to supply the high frequency harmonics of the ripple current, while the electrolytic capacitors provide stored energy over a longer time scale. The net result is significantly reduced heating of the electrolytic capacitors, which translates directly into much longer service life. Note that this is directly analogous to the use of bypass capacitors at the circuit board level [3], but can only be realized at high power levels (e.g. 100kW and up) with very high performance film capacitors. An additional advantage is the elimination of snubber (bypass) capacitors at the switch inputs as a result of the very low inductance presented by the film capacitors with a properly designed interconnection.

2. Circuit Analysis

The term "ripple current" is generically utilized across the power electronics industry to specify DC link capacitors. While this number is typically defined in datasheets at a single frequency (e.g. 120Hz), the reality is that ripple current occupies a wide frequency spectrum [4]. In order to optimize the hybrid film/electrolytic approach, a detailed circuit model was developed (see Fig. 1) using MicroCap10 [5] to illustrate ripple current harmonic content subject to factors including modulation scheme, switching frequency, and switch transition time. The model represents a 250kW inverter using pulse width modulation at a switching frequency of 2.7kHz with a modulation index of 0.9 and a switch transition time of approximately 1 μ s.

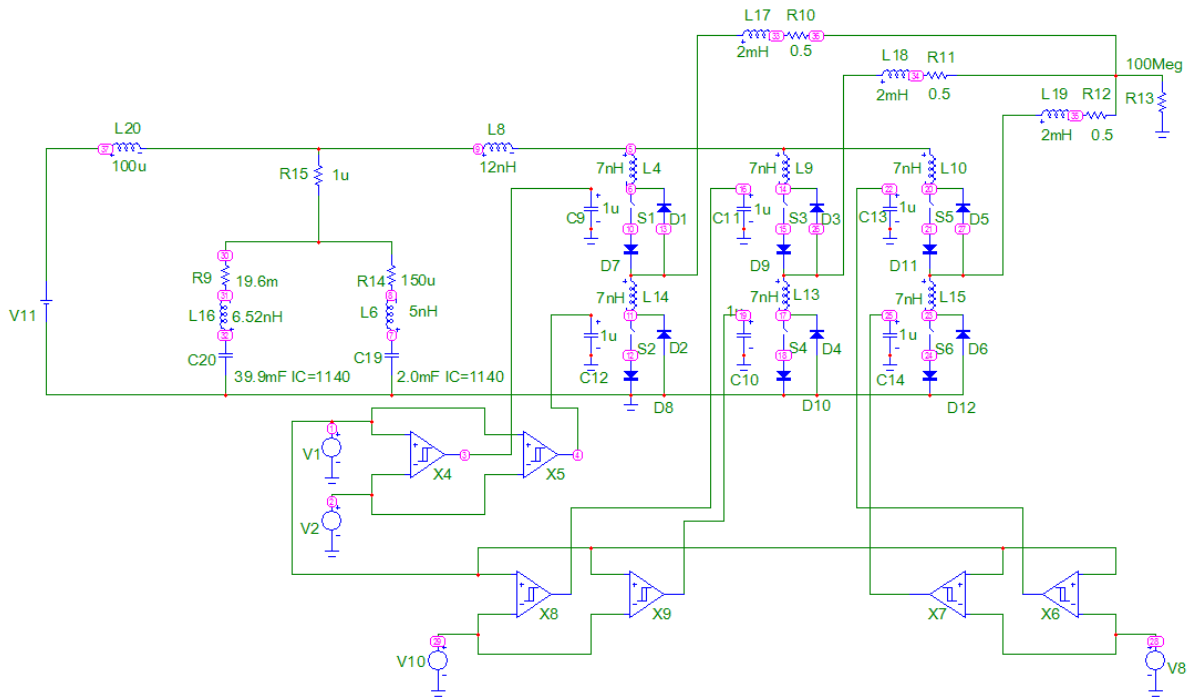

Fig. 1. Inverter equivalent circuit for simulation of DC link ripple current spectrum.

Consider a 40mF electrolytic bank operating under these conditions, which has a ripple current spectrum represented by the red curve in Fig. 2. The parallel addition of a 2mF SBE Power Ring Film Capacitor™ creates a low pass filter as shown in Fig. 3, which significantly attenuates the electrolytic harmonic content. This attenuation is represented by the green curve in Fig. 2. The addition of the film “hardener” reduces the power dissipated in the electrolytic bank by a factor of three and the total electrolytic bank current is now 60% of the original value. Assuming that the electrolytic bank originally operates at a ripple current multiplier of one, the addition of the film capacitor extends the life of the electrolytic bank by more than 10 years (based on typical electrolytic manufacturer’s data).

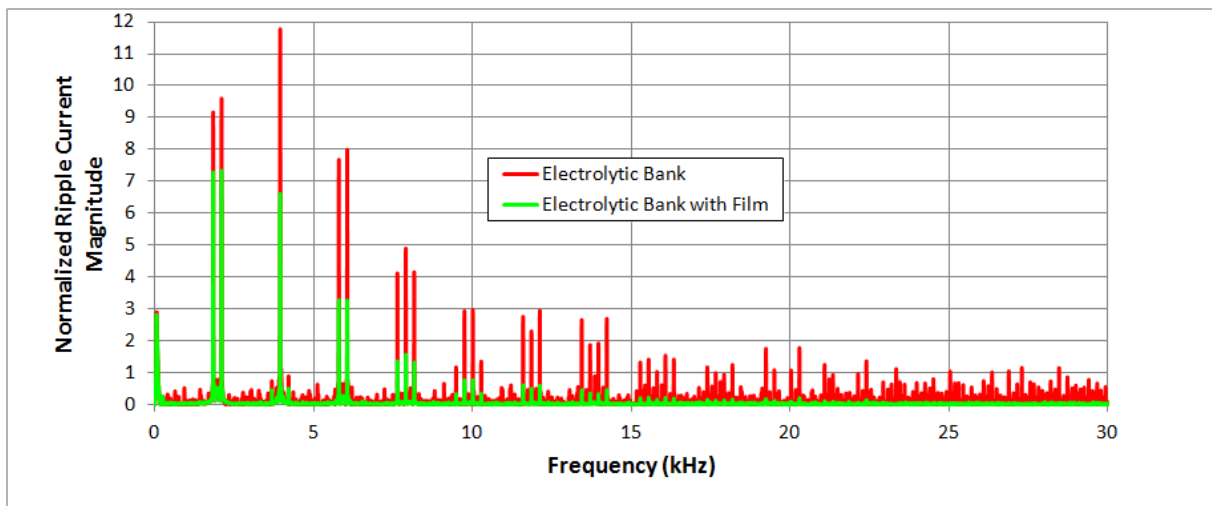

Fig. 2. Illustration of ripple current harmonic reduction by adding a parallel 2mF Power Ring Film Capacitor™ to an existing 40mF electrolytic bank.

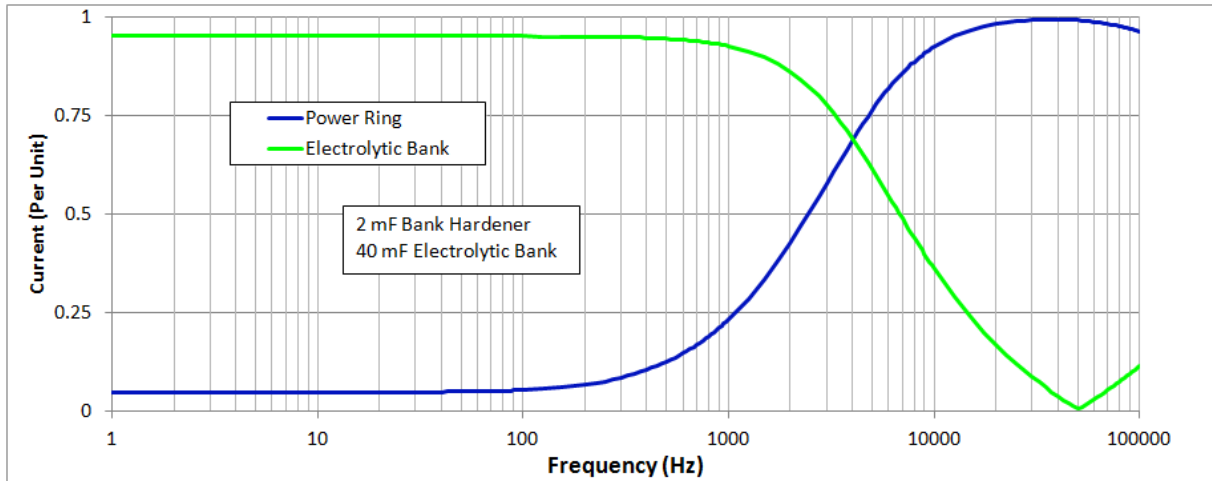

Fig. 3. Low pass filter response created by parallel addition of film capacitor to electrolytic bank.

3. A Practical Illustration

Now consider a 250kW inverter for alternative energy applications where ripple current on the order of 400Arms must be sourced by the DC link capacitor bank. A typical bus voltage of $1000V_{dc}$ will require series strings of three 500V electrolytic caps and the number of parallel branches is determined by the ripple current rating or the total capacitance required for ride-through. Using an industry standard 5.4mF electrolytic building block rated at 20Arms, a total of 20 branches and 60 cans are required to safely manage 400Arms with a total bank value of 36mF.

3.1 Analysis

The analysis method described in the previous section was used to evaluate scenarios for adding film capacitors in parallel with the electrolytic bank as shown in Table 1 assuming a 2.7kHz switching frequency and the same PWM parameters discussed previously. With 1.5mF of film, the number of electrolytic branches can be safely reduced from 20 to 10 such that only 30 cans are required for a total bank value of 18mF. The low pass filter and ripple current spectral content reduction are quite similar to what was presented in Fig. 2 and Fig. 3. A full-scale demonstrator module has been built for evaluation as shown in Fig. 4 with two 0.75mF Power Ring Film CapacitorsTM deployed back to back (in parallel) on a laminar bus structure between the electrolytic bank and switch module inputs. Note that the film capacitors fit within the electrolytic cross section such that the hybrid bank can be easily installed in an existing inverter designed for a 3 x N electrolytic bank.

	ELECTROLYTIC					FILM			
	Bank	Bank	Bank	Bank	Branch	C (mF)	ESR ($\mu\Omega$)	P (W)	I_{rms} (A)
Branches	C (mF)	ESR (m Ω)	P (W)	I_{rms} (A)	I_{rms} (A)	C (mF)	ESR ($\mu\Omega$)	P (W)	I_{rms} (A)
20	36.00	15.70	2487	398.00	19.90	NA	NA	NA	NA
20	36.00	15.70	1154	271.11	13.56	1.5	150	11.96	282.37
13	23.40	24.10	1246	227.38	17.49	1.5	150	15.18	318.10
11	19.80	28.50	1252	209.59	19.05	1.5	150	16.40	330.66
10	18.00	31.30	1244	199.36	19.94	1.5	150	17.02	336.85

Table 1. Optimization scenarios for reducing a 36mF electrolytic bank by addition of parallel film capacitors (2.7kHz switching frequency).



Fig. 4. Photograph of the full-scale prototype hybrid DC link capacitor bank with 18mF electrolytic and 1.5mF film.

The benefit to the electrolytic capacitors is realized by increasing the total current sourced by the film capacitors and the reliability implications of this must be considered. The advantage of using annular form factor film capacitors is clearly illustrated in Table 1, where the low ESR minimizes the losses. A similar gain is achieved in the thermal resistance, which will be on the order of 2.3°C/W for each of the 0.75mF film capacitor sections. Assuming 8.5W in each film section, the hotspot temperatures will be approximately 75°C assuming the cases are at 55°C ambient. SBE has performed extensive life testing on similar capacitor sections for automotive applications at 105°C coolant [6] and the results indicate that an MTTF of > 300,000 hours can be achieved under these conditions.

3.2 Bench Testing

The hybrid capacitor bank was tested using the electrical circuit shown in Fig. 5 as illustrated in the setup photograph presented in Fig. 6. The intention of this test was to focus on a single inverter switching event and demonstrate the current pull from the electrolytic capacitors with and without the 1.5mF film “hardener” capacitors installed. Three 12V car batteries in series were used to charge the capacitor bank to 36V and a Fuji 2MBI225VN-

120-50 (V Series) half-bridge was turned on to connect a 0.1Ω load across the bank. The current through the load resistor and a selected branch of the electrolytic bank were measured using Pearson™ current transformers.

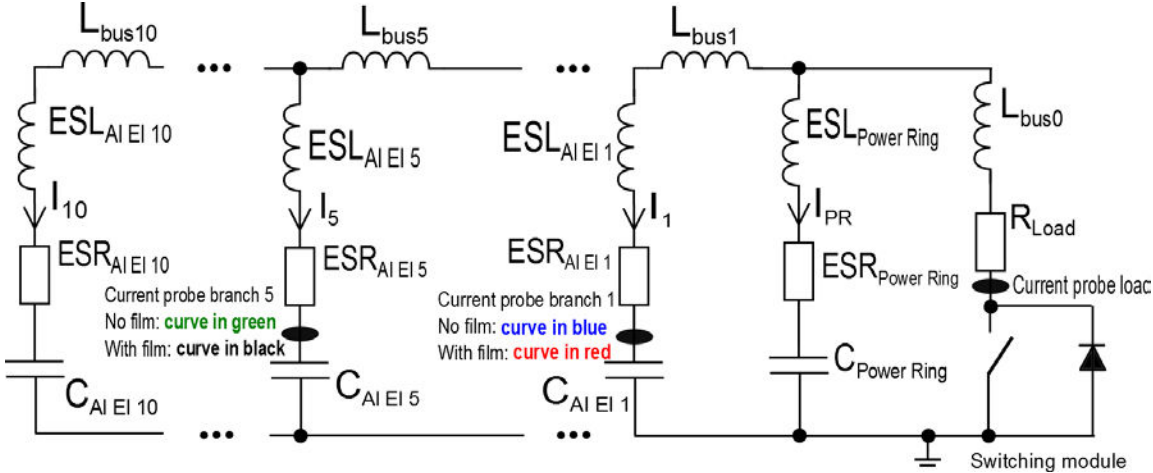

Fig. 5. Illustration of the hybrid DC link capacitor prototype equivalent circuit.

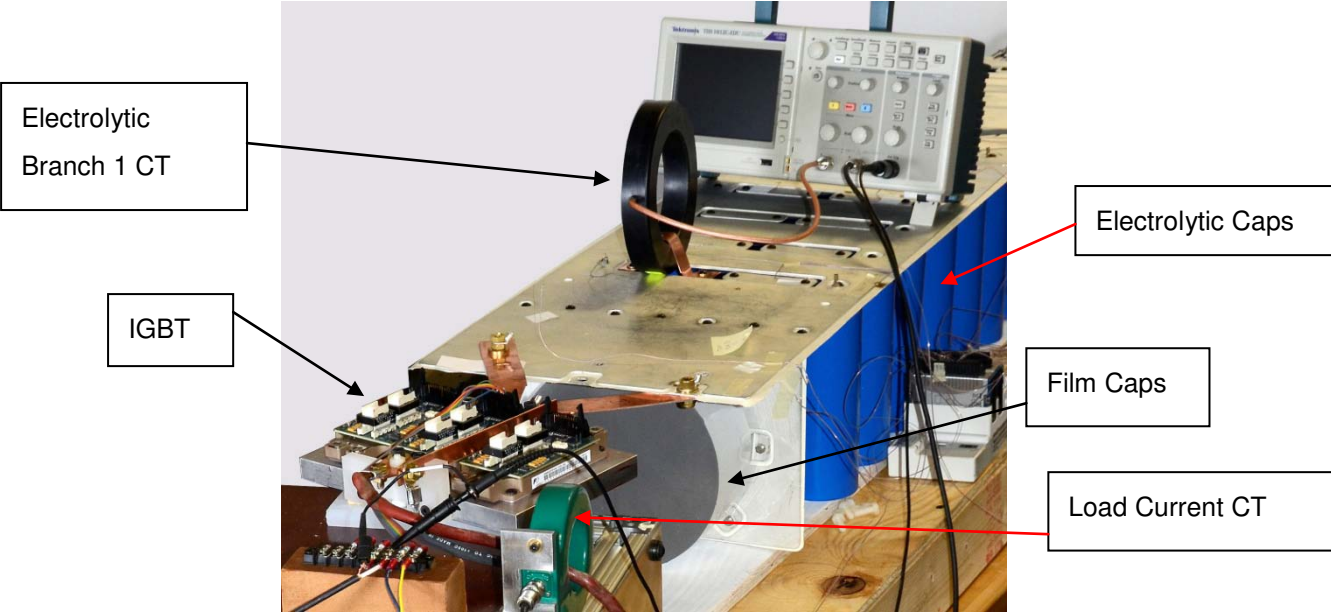

Fig. 6. Photograph of the hybrid DC link capacitor prototype bench testing configuration.

A $100\mu s$ pulse length was selected to provide a representative frequency spectrum for 2.7kHz switching having similar ripple current harmonics and low pass filter response to those shown in Fig. 2 and Fig. 3. Typical results are presented in Fig.7, which compares the current in electrolytic branches 1 and 5 (see Fig. 5) with and without film. The effect of the low pass filter provided by the film capacitors is clearly evident in the rising edge of the current waveform. During the later portion of pulse window, the frequency content is significantly lower and the current is defined by the capacitance ratio between the film and

electrolytic values. Note that this testing was performed using new electrolytic capacitors, and the results do not show the effect of higher ESR due to aging. Further testing is in progress to evaluate the effect of higher electrolytic branch ESR.

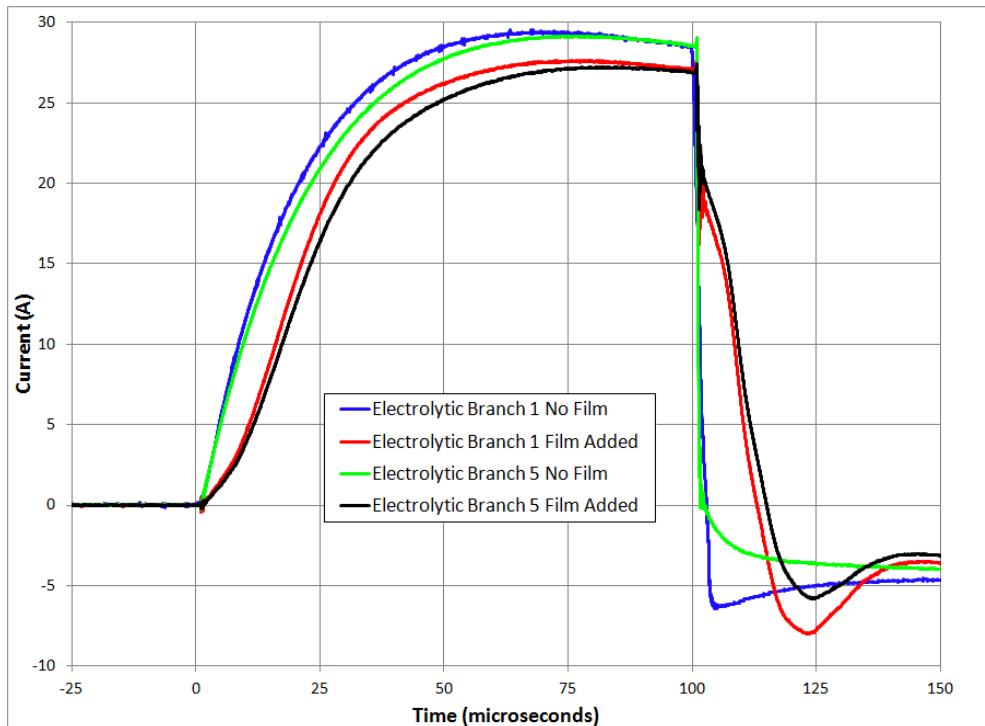

Fig. 7. Comparison of electrolytic branch currents during a switching event with and without the 1.5mF film capacitor installed.

The 100 μ s pulse length is convenient to show the behavior of the electrolytic capacitor in the fast and slow time regimes. The film capacitor advantage is maximized for shorter pulse durations having higher frequency content as illustrated in Figure 8. This shows an expanded time window for the electrolytic branch 1 currents with and without the film capacitors. The impact of the bank hardener on the electrolytic branch losses is compared for 10, 25 and 50 μ s showing respective reductions of 90%, 60% and 30%. While the rise time in the existing setup is presently limited, the low pass filter provided by the film capacitors is clearly having the desired effect. Further work is in progress to reduce the pulse rise time in the bench test setup to match the simulation. Additional testing will also compare heating of the electrolytic capacitors subject to relevant current harmonics with and without the film capacitors.

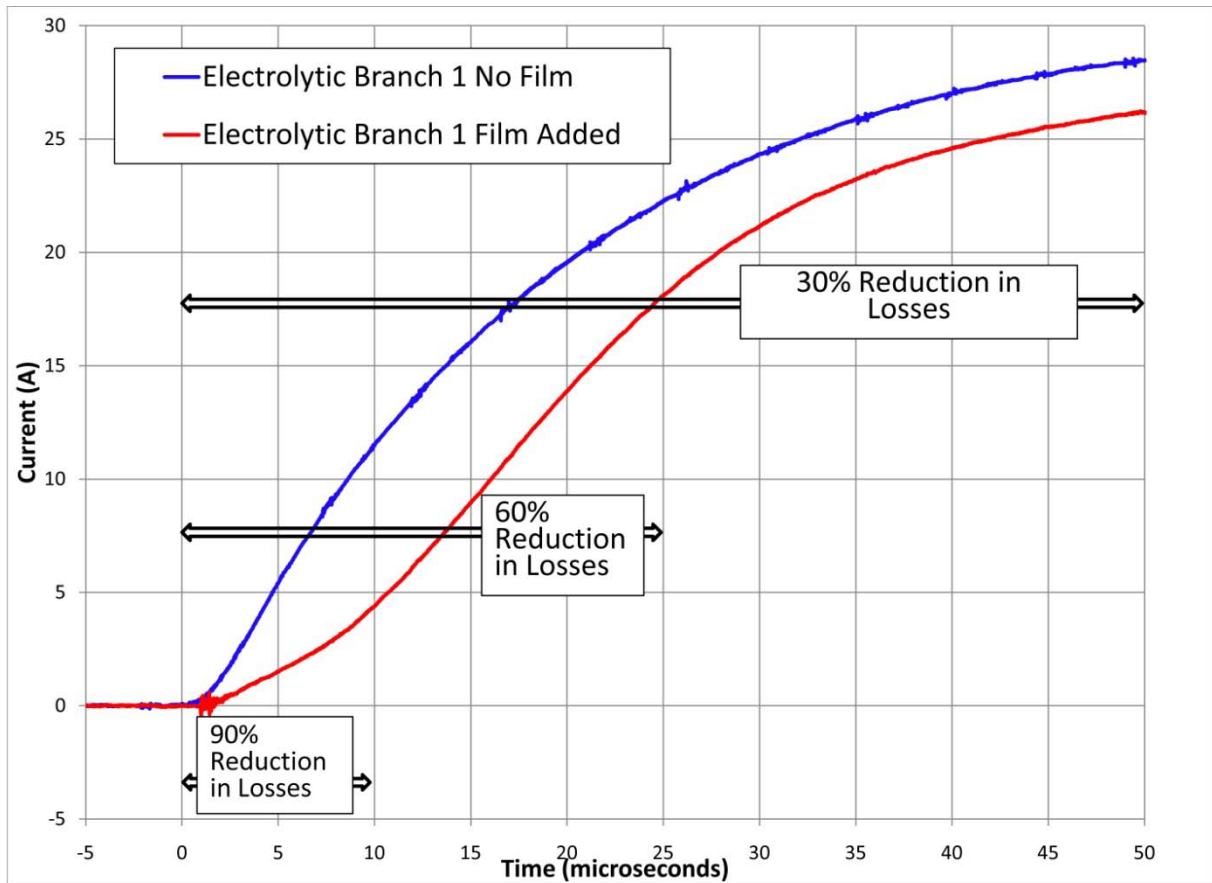

Fig. 8. Comparison of electrolytic branch 1 currents on a shorter time scale with and without the film hardener installed.

4. Conclusion

A hybrid film/electrolytic approach will provide the best possible combination of capacitance density and life for alternative energy DC link capacitor banks. Extensive simulation has demonstrated the efficacy of this approach and simple pulse testing has provided additional validation. The addition of high performance film capacitors can significantly reduce the harmonic currents that must be supplied by a conventional electrolytic bank. This strategy provides new options for cost and volume reduction in wind and solar inverter applications. The ability to eliminate half of a conventional 36mF electrolytic bank through the addition of 1.5mF of film while maintaining a safe operating current is significant. The designer is no longer constrained to select bank capacitance based on ripple current rating and can consider a large cost savings up front. Similarly, the film hardener provides de-rating to extend electrolytic service life with a small addition of capacitance.

5. References

- [1] R. Garcia-Rojo and D. Olalla, "DC Link Capacitors for Industrial Applications", Proceedings of CARTS Europe 2008, October 20-23, Helsinki, Finland, 2008.
- [2] E. D. Sawyer, "Low Inductance - Low Temp Rise DC Bus Capacitor Properties Enabling the Optimization of High Power Inverters", Proceedings of PCIM 2010, May 4-10, Nuremberg, Germany, 2010.
- [3] S. Weir, "Bypass Filter Design Considerations for Modern Digital Systems, A Comparative Evaluation of the Big V, Multi-pole, and Many Pole Bypass Strategies", DesignCon East 2005.

- [4] Brendan Peter McGrath and Donald Grahame Holmes, "A General Analytical Method for Calculating Inverter DC-Link Current Harmonics," IEEE Transactions on Industry Applications, Vol. 45, No. 5, September/October 2009
- [5] MicroCap 10, SPECTRUM SOFTWARE, 1021 South Wolfe Road, Suite 130, Sunnyvale, CA.
- [6] M. A. Brubaker, T. A. Hosking, and T. F. Von Kampen, "Life Testing of High-Value Annular Form Factor DC Link Capacitors for Applications with 105°C Coolant", Proceedings of PCIM 2011, Nuremburg, Germany, May 17-19, 2013.