

For the electronic measurement of current: DC, AC, pulsed..., with galvanic separation between the primary and the secondary circuit.



## Features

- Closed loop (compensated) current transducer using an extremely accurate zero flux detector
- Electrostatic shield between primary and secondary circuit
- 9-pin D-Sub male secondary connector
- Status signal to indicate the transducer state
- LED indicator confirms normal operation
- Metal housing to improve immunity to EMC & power dissipation
- Operating temperature  $-40 \text{ }^{\circ}\text{C}$  to  $85 \text{ }^{\circ}\text{C}$ .

## Advantages

- Very high accuracy
- Excellent linearity
- Extremely low temperature drift
- Wide frequency bandwidth
- High immunity to external fields
- No insertion losses
- Very low noise on output signal
- Low noise feedback to primary conductor.

## Applications

- Feed back element in high performance gradient amplifiers for MRI
- Feedback element in high-precision, high-stability power supplies
- Calibration unit
- Energy measurement
- Medical equipment.

## Standards

- EN 61000-6-2: 2005
- EN 61000-6-3: 2007
- EN 61010-1: 2010.

## Application Domain

- Industrial
- Laboratory
- Medical.

**Insulation coordination**

Parameter	Symbol	Unit	Value	Comment
Rated insulation RMS voltage, basic insulation	$U_{Nm}$	V	1000	IEC 61010-1 conditions - over voltage cat III - pollution degree 2
Rated insulation RMS voltage, reinforced insulation			1000	IEC 61010-1 conditions - over voltage cat III - pollution degree 2
RMS voltage for AC insulation test, 50 Hz, 1 min	$U_d$	kV	6	Between primary and secondary + shield
		V DC	100	Between secondary and test winding
Impulse withstand voltage 1.2/50 $\mu$ s	$U_{Ni}$	kV	12.8	
Clearance (pri. - sec.)	$d_{Cl}$	mm	21	Shortest distance through air
Creepage distance (pri. - sec.)	$d_{Cp}$	mm	22	Shortest path along device body
Comparative tracking index	$CTI$		250	

**Environmental and mechanical characteristics**

Parameter	Symbol	Unit	Min	Typ	Max	Comment
Ambient operating temperature	$T_A$	°C	-40		85	
Ambient storage temperature	$T_{Ast}$	°C	-40		85	
Relative humidity	$RH$	%	20		80	
Dimensions						See drawing in page 8
Mass	$m$	kg		4.2		

**Electrical data**

 At  $T_A = 25\text{ }^\circ\text{C}$ ,  $\pm U_C = \pm 15\text{ V}$ , unless otherwise noted.

 Lines with a \* in the comment column apply over the  $-40 \dots 85\text{ }^\circ\text{C}$  ambient temperature range.

Parameter	Symbol	Unit	Min	Typ	Max		Comment
Primary nominal DC current (continuous)	$I_{P\text{NDC}}$	A	-2000		2000	*	
Primary nominal RMS current	$I_{PN}$	A			2000	*	
Primary current, measuring range	$I_{PM}$	A	-3000		3000	*	
Measuring resistance	$R_M$	$\Omega$	0		1		See curve page 5
Secondary nominal RMS current	$I_{SN}$	A	-1		1	*	
Number of secondary turns	$N_S$			2000			
Resistance of secondary winding	$R_S$	$\Omega$		4			
Maximum withstand primary peak current <sup>1)</sup>	$\hat{I}_{P\text{max}}$	kA	-10		10		@ pulse of 100 ms
Supply voltage positive	$+U_C$	V	14.25	15	15.75		
Supply voltage negative	$-U_C$	V	-15.75	-15	-14.25		
Current consumption positive	$+I_C$	mA	180	200	225		Add $I_S$ for total current consumption
Current consumption negative	$-I_C$		80	89	100		
Output RMS noise current 0 ... 10 Hz <sup>2)</sup>	$I_{no}$	ppm		0.1			
Output RMS noise current 0 ... 10 kHz <sup>2)</sup>				4			
Output RMS noise current 0 ... 160 kHz <sup>2)</sup>				20			
Output peak-to-peak noise current <sup>2)</sup>	$I_{no\text{pp}}$	ppm		50			
Electrical offset current + self magnetization + effect of earth magnetic field <sup>2)</sup>	$I_{OE}$	ppm	-10		10	*	
Temperature coefficient of $I_{OE}$ @ $I_P = 0\text{ A}$	$TCI_{OE}$	ppm/K		0.1			
Offset stability <sup>2)</sup>		ppm/month	-1		1		
Linearity error <sup>2)</sup>	$\varepsilon_L$	ppm		1	2		
				2	3	*	
Delay time to 90 % of the final output value for $I_{P\text{NDC}}$ step	$t_{D90}$	$\mu\text{s}$			1		$di/dt$ of 100 A/ $\mu\text{s}$
Frequency bandwidth ( $\pm 1\text{ dB}$ )	$BW$	kHz		130			Small-signal bandwidth, 0.5 % of $I_{PN}$
Frequency bandwidth ( $\pm 3\text{ dB}$ )	$BW$	kHz		140			
Test current	$I_T$	A			1		
Number of turns (test winding)	$N_T$			200			
Start-up time	$t_{\text{start}}$	s	2	5	15		

**Notes:** <sup>1)</sup> Single pulse only, not AC. The transducer may require a few seconds to return to normal operation when autoreset system is running

<sup>2)</sup> All ppm figures refer to full-scale which corresponds to a secondary nominal RMS current of 1 A.

## Overload protection - Electrical specification - Status

The overload occurs when the primary current  $I_p$  exceeds a trip level such that the fluxgate detector becomes completely saturated and, consequently, the transducer will switch from normal operation to overload mode.

This trip level is guaranteed to be greater than  $I_{pM}$  and its actual value depends on operating conditions such as temperature and measuring resistance.

When this happens, the transducer will automatically begin to sweep in order to lock on the primary current again.

The overload conditions will be:

- The secondary current  $I_s$  generated is a low frequency signal.
- The signal normal operation status (between pin 3 and 8 of the D-sub connector) switches to  $U+$ . In other words, the output transistor is switched off (i.e., no current from collector to emitter). See the status port wiring below.
- The green LED indicator (normal operation status) turns off.

The measuring can resume when the primary current returns in the measuring range between  $-I_{pN}$  and  $+I_{pN}$ . Then the signal normal operation status switches to GND and the green LED indicator (normal operation status) is again lit.

### Status/Interlock port wiring

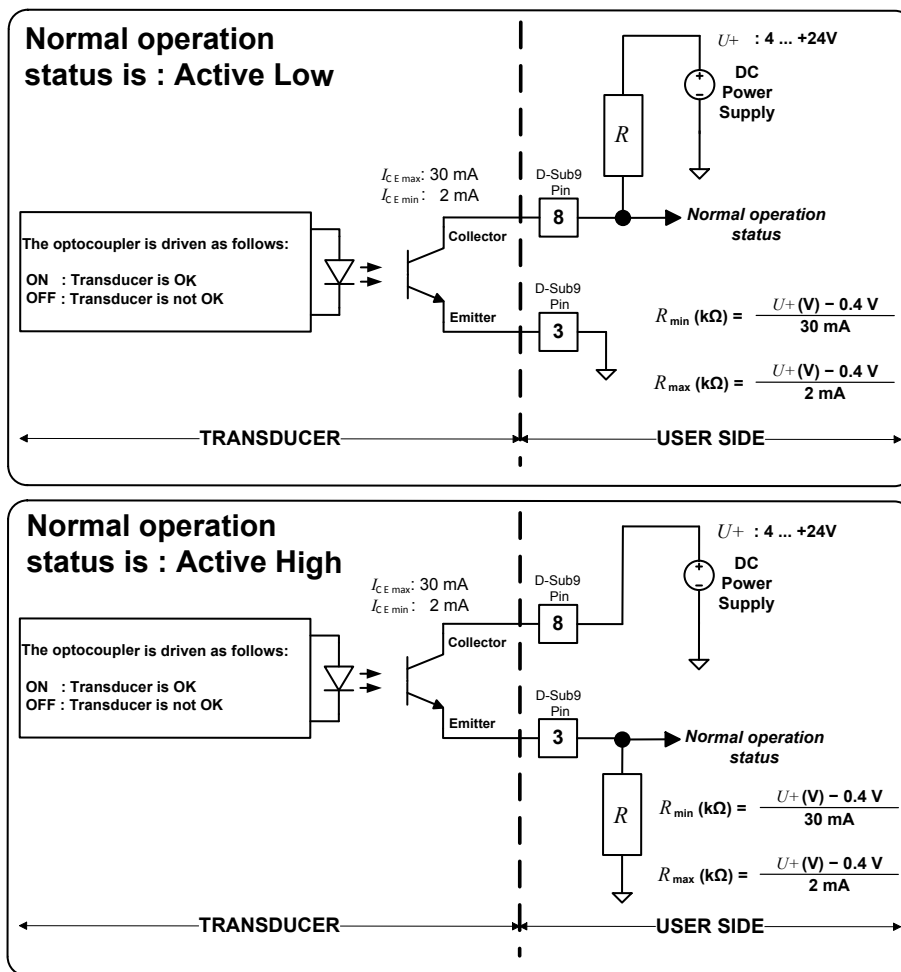

The following table shows how the normal operation status acts as below:

Status	Value	Description
Active Low	$\approx 0.7 \text{ V}$	The transducer is OK (Normal operation)
	$U^+$	The transducer is not OK (Overload mode or supply fault)
Active High	$U^+$	The transducer is OK (Normal operation)
	$\approx 0.7 \text{ V}$	The transducer is not OK (Overload mode or supply fault)

The following table shows how the normal operation status acts as below:

Normal operation status	Description
< 0.7 V	The transducer is OK (Normal operation)
U+	The transducer is not OK (Overload mode or supply fault)

### Maximum measuring resistor versus primary current and temperature

$\pm U_c = \pm 14.25 \text{ V}$

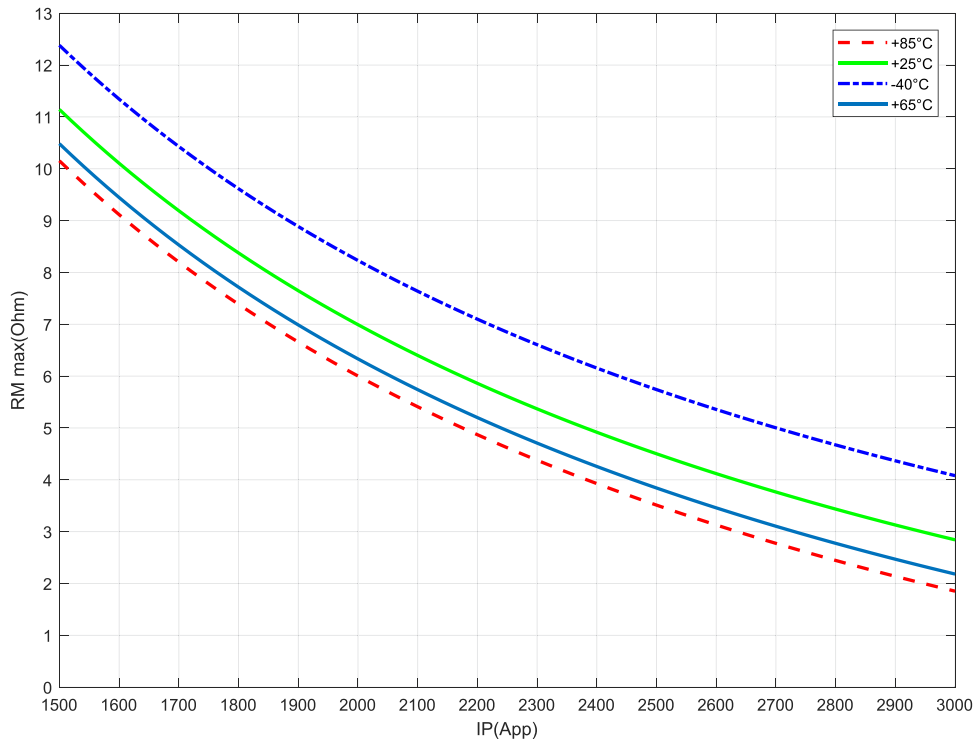
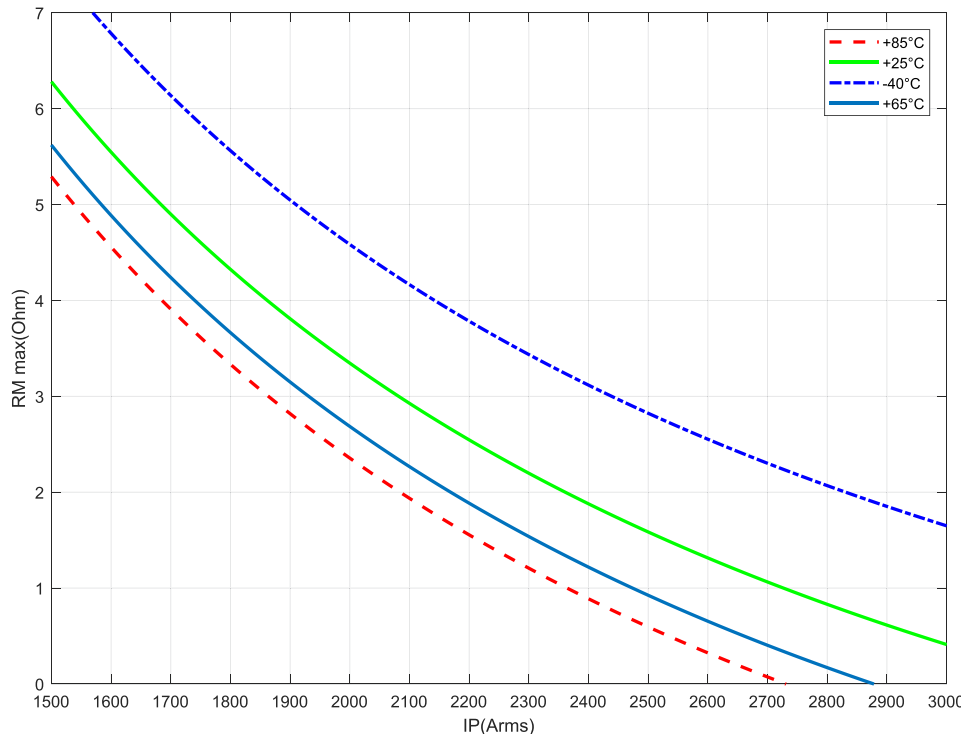

**Power supply and load**

In order to reach the measuring range according to the maximum measuring resistor, be careful with the setup measurement when wires length are high. It means that:

- the wires resistance could be not negligible
- the voltage at the output of the DC power supply and the voltage at the transducer could be significantly different.

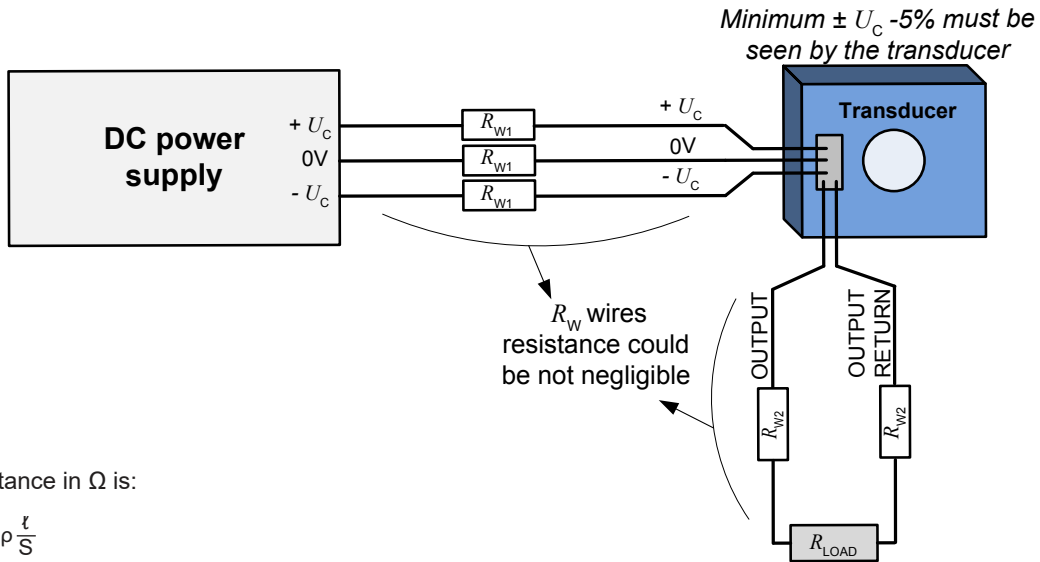

$R_w$  wire resistance in  $\Omega$  is:

$$R_w = \rho \frac{l}{S}$$

- S: Cross section of wire in  $m^2$
- l: Wire length in m
- $\rho$ : Resistivity of material in  $\Omega.m$

**Total measuring resistance is:**

$$R_M = R_L + 2 \times R_{w1} + 2 \times R_{w2}$$

If  $R_{w1} = R_{w2} = R_{WIRE}$  then  $R_M = R_L + 4 \times R_{WIRE}$

## Performance parameters definition

The schematic used to measure all electrical parameters is shown below:

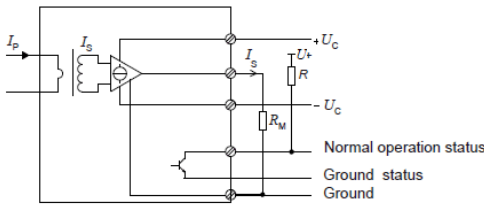

### Transducer simplified model

The static model of the transducer at temperature  $T_A$  is:

$$I_S = N_P/N_S \cdot I_P + \varepsilon$$

In which

$$\varepsilon = I_{OE} \text{ at } 25^\circ\text{C} + I_{OT}(T_A) + \varepsilon_L \cdot I_{PM} \cdot N_P/N_S$$

Where,

$$I_{OT}(T_A) = TCI_{OE} \cdot |T_A - 25^\circ\text{C}| \cdot I_{PM} \cdot N_P/N_S$$

- $I_S$  : secondary current (A)
- $N_P/N_S$  : turns ratio (1:  $N_S$ )
- $I_P$  : primary current (A)
- $I_{PM}$  : primary current, measuring range (A)
- $T_A$  : ambient operating temperature ( $^\circ\text{C}$ )
- $I_{OE}$  : electrical offset current (A)
- $I_{OT}$  : temperature variation of  $I_{OE}$  at  $T_A$  (A)
- $\varepsilon_L$  : linearity error

This is the absolute maximum error. As all errors are independent, a more realistic way to calculate the error would be to use the following formula:

$$\varepsilon = \sqrt{\sum_{i=1}^N \varepsilon_i^2}$$

### Linearity

To measure linearity, the primary current (DC) is cycled from 0 to  $I_{PM}$ , then to  $-I_{PM}$  and back to 0. The linearity error  $\varepsilon_L$  is the maximum positive or negative difference between the measured points and the linear regression line, expressed in parts per million (ppm) of full-scale which corresponds to the maximum measured value.

### Electrical offset

The electrical offset current  $I_{OE}$  is the residual output current when the input current is zero.

The temperature variation  $I_{OT}$  of the electrical offset current  $I_{OE}$  is the variation of the electrical offset from  $25^\circ\text{C}$  to the considered temperature.

### Delay times

The delay time  $t_{D,10}$  @ 10% and the delay time  $t_{D,90}$  @ 90% with respect to the primary are shown in the next figure.

Both slightly depend on the primary current  $di/dt$ . They are measured at nominal current.

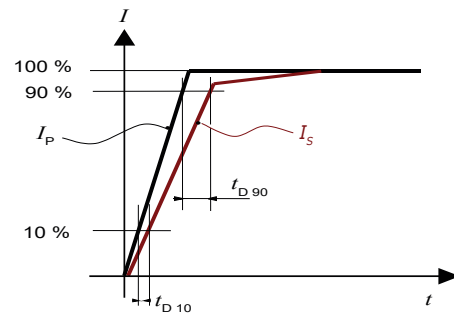

## Safety

This transducer must be used in limited-energy secondary circuits according to IEC 61010-1.



This transducer must be used in electric/electronic equipment with respect to applicable standards and safety requirements in accordance with the manufacturer's operating instructions.



Caution, risk of electrical shock

When operating the transducer, certain parts of the module can carry hazardous voltage (e.g. primary busbar, power supply). Ignoring this warning can lead to injury and/or cause serious damage.

This transducer is a build-in device, whose conducting parts must be inaccessible after installation.

A protective housing or additional shield could be used. Main supply must be able to be disconnected.

## Remark

Installation of the transducer must be done unless otherwise specified on the datasheet, according to LEM Transducer Generic Mounting Rules. Please refer to LEM document N°ANE120504 available on our Web site:

[Products/Product Documentation](#).



