

Current Transducer IN 2000-SB/SP1

$I_{PN} = 2000 \text{ A}$

For the electronic measurement of current: DC, AC, pulsed..., with galvanic separation between the primary and the secondary circuit.

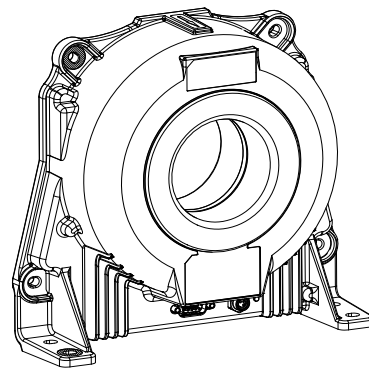

Features

- Closed loop (compensated) current transducer using an extremely accurate zero flux detector
- 9-pin D-Sub male secondary connector
- Status signal to indicate the transducer state
- LED indicator confirms normal operation
- Metal housing to improve immunity to EMC & power dissipation
- Operating temperature $-40 \text{ }^{\circ}\text{C}$ to $85 \text{ }^{\circ}\text{C}$.

Special feature

- Specified $\pm 5 \text{ V}$ voltage output.

Advantages

- Very high accuracy
- Excellent linearity
- Extremely low temperature drift
- Wide frequency bandwidth
- High immunity to external fields
- No insertion losses
- Low noise on output signal
- Low noise feedback to primary conductor.

Applications

- Feedback element in high performance gradient amplifiers for MRI
- Feedback element in high precision, high-stability power supplies
- Calibration unit
- Energy measurement
- Medical equipment.

Standards

- EN 61000-6-2: 2005
- EN 61000-6-3: 2007
- EN 61010-1: 2010.

Application Domain

- Industrial
- Laboratory
- Medical.

Insulation coordination

Parameter	Symbol	Unit	Value	Comment
RMS voltage for AC insulation test, 50 Hz, 1 min	U_d	kV	6	Between primary and secondary + shield
		V DC	100	Between secondary and test winding
Impulse withstand voltage 1.2/50 μ s	U_{Ni}	kV	12.8	
Clearance (pri. - sec.)	d_{Cl}	mm	21	Shortest distance through air
Creepage distance (pri. - sec.)	d_{Cp}	mm	22	Shortest path along device body
Comparative tracking index	CTI		250	
Rated insulation RMS voltage	U_{Nm}	V	1000	Basic insulation according to IEC 61010-1 CAT III, PD2
Rated insulation RMS voltage			1000	Reinforced insulation according to IEC 61010-1 CAT III, PD2

Environmental and mechanical characteristics

Parameter	Symbol	Unit	Min	Typ	Max	Comment
Ambient operating temperature	T_A	°C	-40		85	
Ambient storage temperature	T_{Ast}	°C	-40		85	
Relative humidity	RH	%	20		80	
Dimensions						See drawing in p. 7
Mass	m	kg		4.2		

Electrical data

 At $T_A = 25\text{ °C}$, $\pm U_C = \pm 15\text{ V DC}$, $R_L = 1\text{ M}\Omega$ unless otherwise noted.

 Lines with a * in the comment column apply over the $-40 \dots 85\text{ °C}$ ambient temperature range.

Parameter	Symbol	Unit	Min	Typ	Max	Comment
Primary nominal DC current (continuous)	I_{PNDC}	A	-2000		2000	*
Primary nominal AC RMS current (continuous)	I_{PNAC}	A			2000	*
Peak primary current, measuring range	I_{PM}	A	-3000		3000	*
Secondary nominal RMS voltage	U_{SN}	V	-5		5	*
Maximum withstand primary peak current ¹⁾	\hat{I}_P	kA	-10		10	@ pulse of 100 ms
Supply voltage DC	$+U_C$	V	14.25	15	15.75	
	$-U_C$	V	-14.25	-15	-15.75	
Current consumption DC	$+I_C$	A		0.197		* @ $I_P = 0$ To get total consumption at a given I_P add ($I_P/1800$)
	$-I_C$	A		0.11		*
RMS noise voltage 0.1 Hz ... 10 Hz ²⁾	U_{no}	ppm		2		
RMS noise voltage 0.1 Hz ... 10 kHz ²⁾				4		
RMS noise voltage 0.1 Hz ... 160 kHz ²⁾				10		
RMS noise voltage 0.1 Hz ... 1 MHz ²⁾				16		
Peak-to-peak noise voltage	$U_{no,pp}$	ppm		18		
Sensitivity	S	V/A		1/400		
Sensitivity error ²⁾	ε_S	ppm	-75		75	
			-300		300	*
Temperature coefficient of S	TCS	ppm/°C	-2.4		2.4	*
Electrical offset voltage + self magnetization + effect of earth magnetic field ²⁾	U_{OE}	ppm	-20		20	
			-80		80	*
Temperature coefficient of $U_{OE} @ I_P = 0\text{ A}$ ²⁾	TCU_{OE}	ppm/°C	-0.7		0.7	*
Linearity error ²⁾	ε_L	ppm	-30		30	
			-40		40	*
Delay time to 90 % of the final output value for I_{PNDC} step	t_{D90}	μs			1	di/dt of 100 μs
Frequency bandwidth ($\pm 1\text{ dB}$)	BW	kHz		113		Small-signal bandwidth, 0.5 % of I_{PN}
Test current	I_T	A			1	
Number of turns (test winding)	N_T			200		
Start-up time	t_{start}	s	2	5	15	

Notes: ¹⁾ Single pulse only, not AC. The transducer may require a few seconds to return to normal operation when autoreset system is running.

²⁾ All ppm figures refer to full-scale which corresponds to a secondary nominal voltage of I_{PN} .

Overload protection - Electrical specification - Status

The overload occurs when the primary current I_p exceeds a trip level such that the fluxgate detector becomes completely saturated and, consequently, the transducer will switch from normal operation to overload mode.

This trip level is guaranteed to be greater than I_{PM} and its actual value depends on operating conditions such as temperature and measuring resistance.

When this happens, the transducer will automatically begin to sweep in order to lock on the primary current again.

The overload conditions will be:

- The secondary current I_s generated is a low frequency signal.
- The signal normal operation status (between pin 3 and 8 of the D-sub connector) switches to $U+$ or $\approx 0.7 V$. See the status port wiring below.
- The green LED indicator (normal operation status) turns off.

The measuring can resume when the primary current returns in the measuring range between $-I_{PN}$ and $+I_{PN}$. Then the signal normal operation status switches to GND and the green LED indicator (normal operation status) switches on.

Status/Interlock port wiring

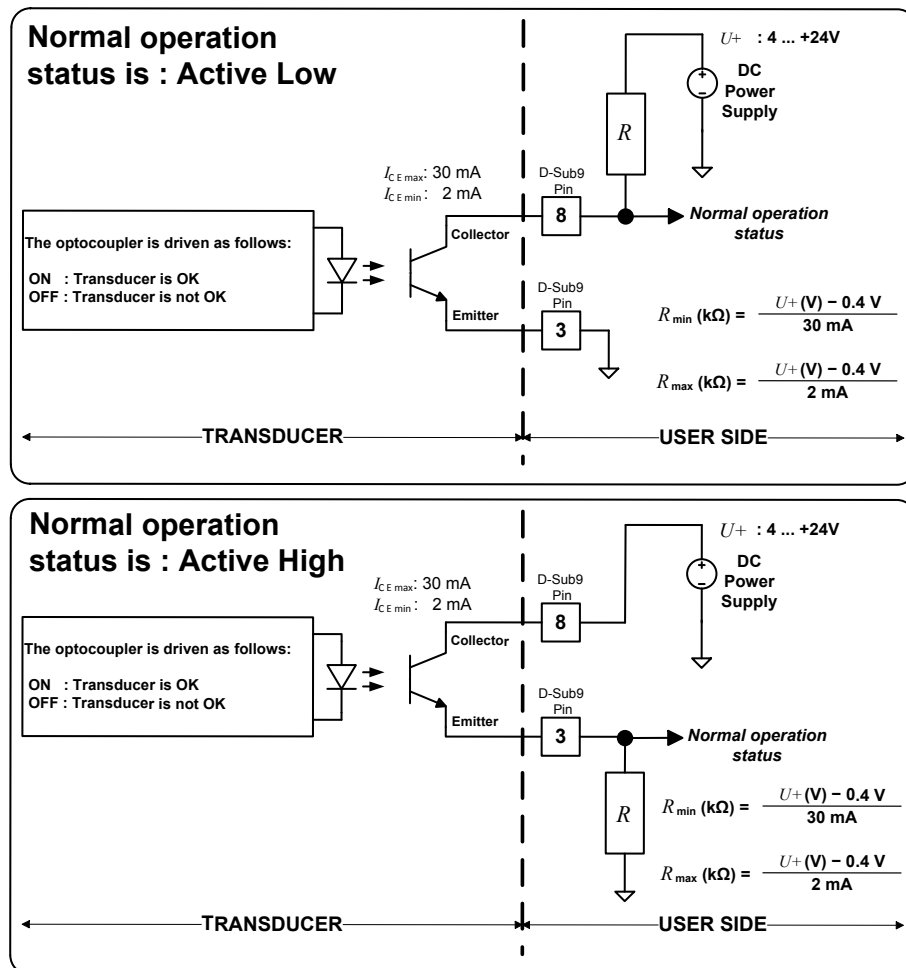

The following table shows how the normal operation status acts as below:

Status	Value	Description
Active Low	$\approx 0.7 V$	The transducer is OK (Normal operation)
	$U+$	The transducer is not OK (Overload mode or supply fault)
Active High	$U+$	The transducer is OK (Normal operation)
	$\approx 0.7 V$	The transducer is not OK (Overload mode or supply fault)

Performance parameters definition

The schematic used to measure all electrical parameters is shown below:

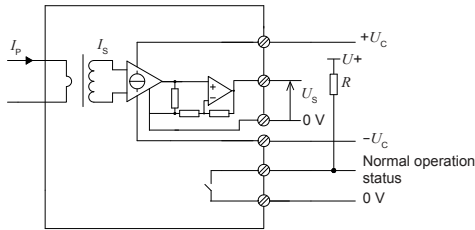

Transducer simplified model

The static model of the transducer at temperature T_A is:

$$U_s = S \cdot I_p + \varepsilon$$

In which

$$\varepsilon = U_{OE} \text{ at } 25^\circ\text{C} + U_{OT}(T_A) + \varepsilon_L \cdot I_{PM} \cdot S$$

Where,

$$U_{OT}(T_A) = TCU_{OE} \cdot |T_A - 25^\circ\text{C}| \cdot I_{PM} \cdot S$$

- U_s : secondary voltage (V)
- S : sensitivity (V/A)
- I_p : primary current (A)
- I_{PM} : primary current, measuring range (A)
- T_A : ambient operating temperature ($^\circ\text{C}$)
- U_{OE} : electrical offset voltage (V)
- U_{OT} : temperature variation of U_{OE} at T_A (V)
- ε_L : linearity error

This is the absolute maximum error. As all errors are independent, a more realistic way to calculate the error would be to use the following formula:

$$\varepsilon = \sqrt{\sum_{i=1}^N \varepsilon_i^2}$$

Linearity

To measure linearity, the primary current (DC) is cycled from 0 to I_{PM} , then to $-I_{PM}$ and back to 0. The linearity error ε_L is the maximum positive or negative difference between the measured points and the linear regression line, expressed in parts per million (ppm) of full-scale which corresponds to the maximum measured value.

Electrical offset

The electrical offset voltage U_{OE} is the residual output voltage when the input current is zero.

The temperature variation U_{OT} of the electrical offset voltage U_{OE} is the variation of the electrical offset from 25°C to the considered temperature.

Delay times

The delay time t_{D10} and the delay time t_{D90} are shown in the figure below.

Both slightly depend on the primary current di/dt . They are measured at nominal current.

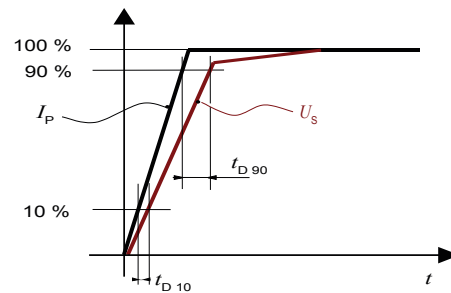

t_{D10} (delay time @ 10 %) and t_{D90} (delay time @ 90 %)

Safety

This transducer must be used in limited-energy secondary circuits according to IEC 61010-1.



This transducer must be used in electric/electronic equipment with respect to applicable standards and safety requirements in accordance with the manufacturer's operating instructions.



Caution, risk of electrical shock

When operating the transducer, certain parts of the module can carry hazardous voltage (e.g. primary busbar, power supply). Ignoring this warning can lead to injury and/or cause serious damage.

This transducer is a build-in device, whose conducting parts must be inaccessible after installation.

A protective housing or additional shield could be used. Main supply must be able to be disconnected.

