

# Current Transducer IT 400-S ULTRASTAB

$I_{PM} = 400 \text{ A}$

For ultra-high precision measurement of current: DC, AC, pulsed..., with galvanic separation between primary and secondary.



## Features

- Closed loop (compensated) current transducer using an extremely accurate zero flux detector
- Electrostatic shield between primary and secondary circuit
- 9-pin D-Sub male secondary connector
- Optically insulated output (photocoupler type) indicates transducer state
- LED indicator confirms normal operation.

## Advantages

- Very high accuracy
- Excellent linearity
- Extremely low temperature drift
- Wide frequency bandwidth
- High immunity to external fields
- No insertion losses
- Low noise on output signal
- Low noise feedback to primary conductor.

## Applications

- Feed back element in high performance gradient amplifiers for MRI
- Feedback element in high-precision, high-stability power supplies
- Calibration unit
- Energy measurement
- Medical equipment.

## Standards

- EN 61000-6-2: 2005
- EN 61000-6-3: 2007
- EN 61010-1: 2010.

## Application Domains

- Industrial
- Laboratory
- Medical.

**Insulation coordination**

Parameter	Symbol	Unit	Value	Comment
Rated insulation rms voltage, basic insulation	$U_b$	V	2000	IEC 61010-1 conditions - over voltage cat III - pollution degree 2
Rated insulation rms voltage, reinforced insulation	$U_b$	V	600	IEC 61010-1 conditions - over voltage cat III - pollution degree 2
Rated insulation rms voltage, basic insulation	$U_b$	V	1000	EN 50178 conditions - over voltage cat III - pollution degree 2
Rated insulation rms voltage, reinforced insulation	$U_b$	V	600	EN 50178 conditions - over voltage cat III - pollution degree 2
Rms voltage for AC insulation test, 50/60 Hz, 1 min	$U_d$	kV	5.4	Between primary and secondary + shield
		V DC	200	Between secondary and shield
		V DC	300	Between secondary and status output
Impulse withstand voltage 1.2/50 $\mu$ s	$\hat{U}_w$	kV	9.9	
Clearance (pri. - sec.)	$d_{Cl}$	mm	11	Shortest distance through air
Creepage distance (pri. - sec.)	$d_{cp}$	mm	11	Shortest path along device body
Comparative tracking index	$CTI$		600	

If insulated cable is used for the primary circuit, the voltage category could be improved with the following table (for single insulation) (IEC 61010-1 standard):

Cable insulated (primary)	Category
HAR03	2150 V CAT III
HAR05	2250 V CAT III
HAR07	2350 V CAT III

**Environmental and mechanical characteristics**

Parameter	Symbol	Unit	Min	Typ	Max	Comment
Ambient operating temperature	$T_A$	°C	10		50	
Ambient storage temperature	$T_S$	°C	-20		85	
Relative humidity	$RH$	%	20		80	Non-condensing
Dimensions						See drawing page 7
Mass	$m$	kg		0.3		

**Electrical data**

 At  $T_A = 25\text{ °C}$ ,  $\pm U_C = \pm 15\text{ V}$ , unless otherwise noted.

Parameter	Symbol	Unit	Min	Typ	Max	Comment
Primary continuous direct current	$I_{PNDC}$	A	-400		400	
Primary nominal rms current	$I_{PN}$	A			282	
Primary current, measuring range	$I_{PM}$	A	-400		400	
Measuring resistance over operating temperature and supply voltage ranges	$R_M$	$\Omega$	0		2.5	See graph page 5
Secondary current	$I_S$	mA	-200		200	
Conversion ratio	$K_N$			1:2000		
Resistance of secondary winding	$R_S$	$\Omega$		40		
Overload capability <sup>1)</sup>	$\hat{I}_P$	A	-2000		2000	@ pulse of 100 ms
Supply voltage	$U_C$	V	$\pm 14.25$	$\pm 15$	$\pm 15.75$	
Current consumption	$I_C$	mA			80	Add $I_S$ for total current consumption
Output rms noise 0 ... 10 Hz <sup>2)</sup>	$V_{no}$	ppm			0.05	
Output rms noise 0 ... 100 Hz <sup>2)</sup>					0.5	
Output rms noise 0 ... 1 kHz <sup>2)</sup>					1	
Output rms noise 0 ... 10 kHz <sup>2)</sup>					4	
Output rms noise 0 ... 50 kHz <sup>2)</sup>					8	
Re-injected rms noise on primary bus bar		$\mu\text{V}$			5	0 ... 50 kHz
Electrical offset current + self magnetization + effect of earth magnetic field <sup>2)</sup>	$I_{OE}$	ppm			40	
Temperature coefficient of $I_{OE}$ <sup>2)</sup>	$TCI_{OE}$	ppm/K			1	10 °C ... 50 °C
Offset stability <sup>2)</sup>		ppm/month			1	
Linearity error <sup>2)</sup>	$\epsilon_L$	ppm			3	
Step response time to 90 % of $I_{PNDC}$	$t_r$	$\mu\text{s}$			1	$di/dt$ of 80 A/ $\mu\text{s}$
$di/dt$ accurately followed	$di/dt$	A/ $\mu\text{s}$	80			
Frequency bandwidth ( $\pm 1\text{ dB}$ )	$BW$	kHz	0	150		Small-signal bandwidth, 0.5 % of $I_{PM}$
Frequency bandwidth ( $\pm 3\text{ dB}$ )	$BW$	kHz	0	500		Small-signal bandwidth, 0.5 % of $I_{PM}$

**Notes:** <sup>1)</sup> Single pulse only, not AC. The transducer may require a few seconds to return to normal operation when autoreset system is running  
<sup>2)</sup> All ppm figures refer to full-scale which corresponds to a secondary current ( $I_S$ ) of 200 mA.

## Overload protection - Electrical specification - Status

The overload occurs when the primary current  $I_p$  exceeds a trip level such that the fluxgate detector becomes completely saturated and, consequently, the transducer will switch from normal operation to overload mode.

This trip level is guaranteed to be greater than 110 % of  $I_{PNDC}$  and its actual value depends on operating conditions such as temperature and measuring resistance.

When this happens, the transducer will automatically begin to sweep in order to lock on the primary current again.

The overload conditions will be:

- The secondary current generated is a low frequency signal between  $-200$  mA and  $200$  mA.
- The signal  $V_{out}$  (operation status between pin 3 and 8 of the D-sub connector) switches to V+ or GND depending on how it is wired. In other words, the output transistor is switched off (i.e., no current from collector to emitter). See the status port wiring below.
- The green LED indicator (normal operation status) turns off.

The measuring can resume when the primary current returns in the nominal range between  $-I_{PNDC}$  and  $+I_{PNDC}$ . Then the signal  $V_{out}$  switches to V+ or GND and the green LED indicator (normal operation status) is again lit.

**TO ENSURE A SAFE RECOVERY FROM SATURATION, THE MAXIMUM BURDEN RESISTOR ALLOWED IS 2.5  $\Omega$ .**

## Status/Interlock port wiring

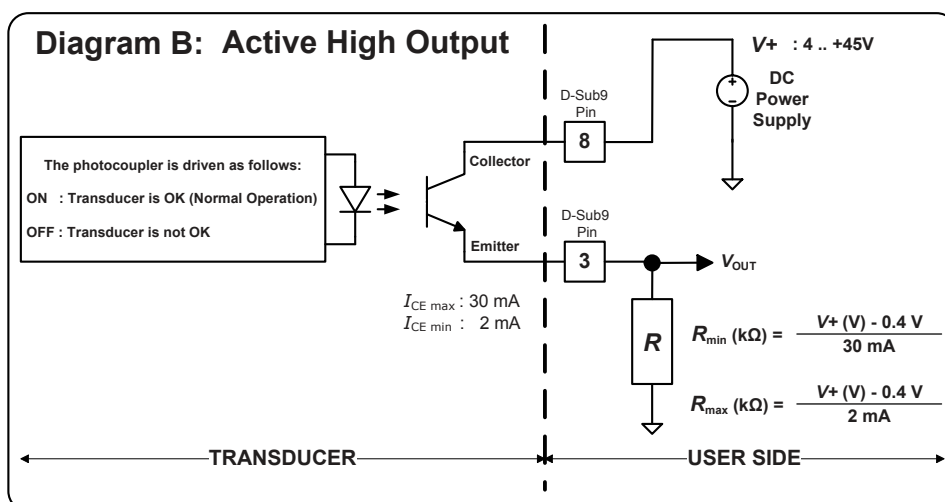
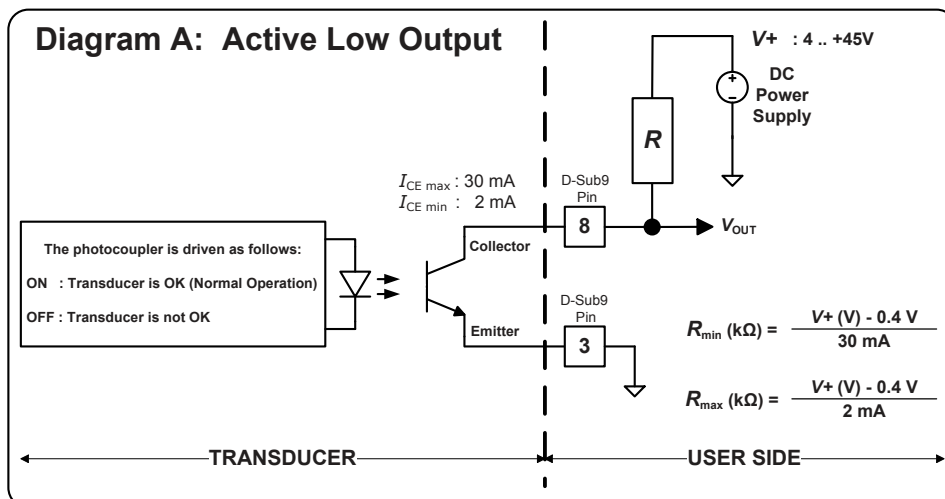

The following table shows how the output signal  $V_{out}$  acts depending on how it is wired:

Case	$V_{out}$	Description
Diagram A	< 0.2 V	The transducer is OK (Normal operation)
	V+	The transducer is not OK (Overload mode or supply fault)
Diagram B	< 0.2 V	The transducer is not OK (Overload mode or supply fault)
	V+	The transducer is OK (Normal operation)

Some recommended standard values of  $R$ :

Power supply voltage V+	$R_{min}$ (k $\Omega$ )	$R_{max}$ (k $\Omega$ )	$R$ standard values $\pm 5\%$
5 V	0.153	2.3	180 $\Omega$ , 1 k $\Omega$ or 2.2 k $\Omega$
12 V	0.386	5.8	470 $\Omega$ , 2.2 k $\Omega$ or 4.7 k $\Omega$
24 V	0.786	11.8	1 k $\Omega$ , 2.2 k $\Omega$ or 10 k $\Omega$

### Electrical data - status port

Parameter	Symbol	Unit	Min	Typ	Max	Comment
Collector-Emitter voltage, off-state	$V_{CE\ off}$	V	4		45	
Collector-Emitter current, on-state	$I_{CE}$	mA	2		30	
Reverse Collector-Emitter voltage, off-state	$V_{CER\ off}$	V			5	
Collector-Emitter voltage, on-state	$V_{CE\ on}$	V			0.2	

### Maximum measuring resistor versus primary current

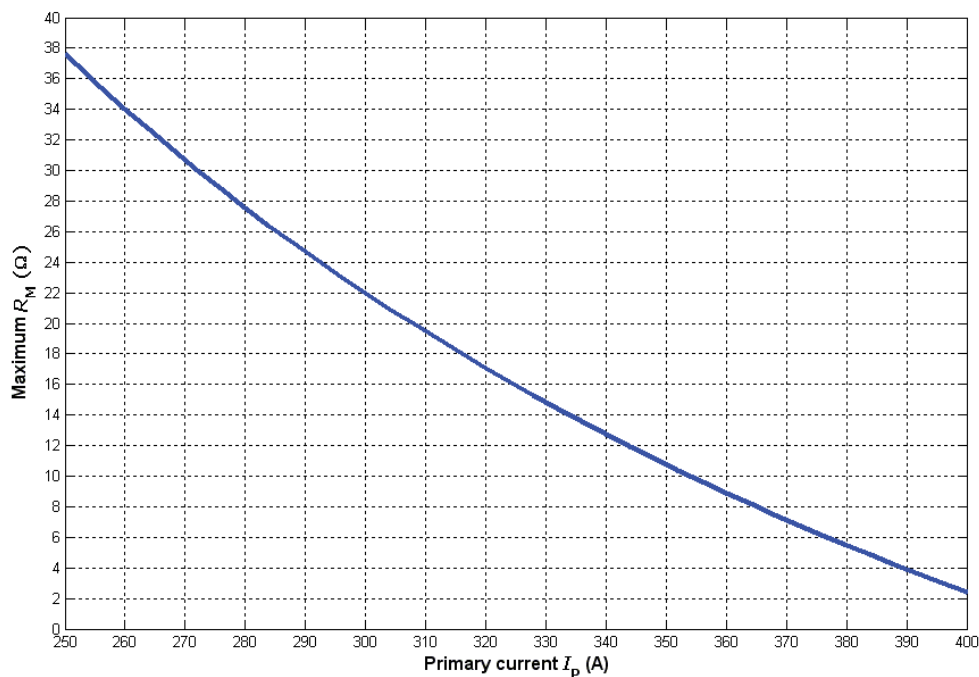

## Safety

This transducer must be used in limited-energy secondary circuits according to IEC 61010-1.



This transducer must be used in electric/electronic equipment with respect to applicable standards and safety requirements in accordance with the manufacturer's operating instructions.



Caution, risk of electrical shock

When operating the transducer, certain parts of the module can carry hazardous voltage (eg. primary busbar, power supply). Ignoring this warning can lead to injury and/or cause serious damage.

This transducer is a build-in device, whose conducting parts must be inaccessible after installation.

A protective housing or additional shield could be used.

Main supply must be able to be disconnected.

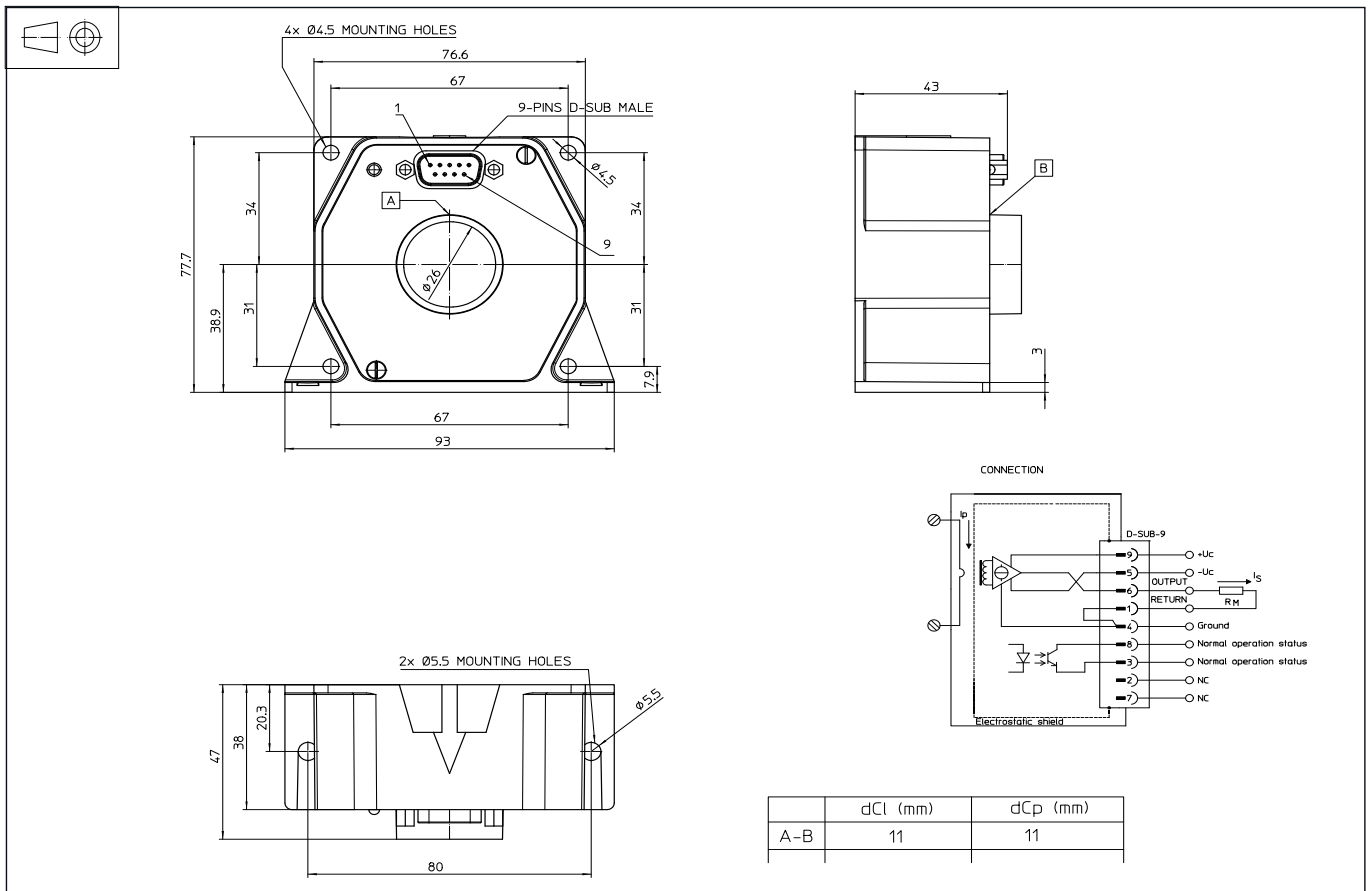
**Dimensions (in mm)**

**Connection**

- Normal operation status (Pins 3 and 8)  
Normal operation means:
  - $\pm 15\text{ V}$  ( $\pm U_C$ ) present
  - zero detector is working
  - primary current  $\leq 110\%$  of  $I_{PN\ DC}$
  - green LED indicator is lit.

**Remarks**

- $I_S$  is positive when  $I_P$  flows in the direction of the arrow.
- We recommend that a shielded output cable and plug are used to ensure the maximum immunity against electrostatic fields.
- Pin 4 should be connected to cable and connector shield to maintain lowest output noise.
- Temperature of the primary conductor should not exceed  $50\text{ }^\circ\text{C}$ .

**Mechanical characteristics**

- General tolerance  $\pm 0.3\text{ mm}$
- Transducer fastening
  - Straight mounting 2 holes  $\varnothing 5.5\text{ mm}$   
2 x M5 steel screws  
Recommended fastening torque 3.7 N·m
  - Flat mounting 4 holes  $\varnothing 4.5\text{ mm}$   
4 x M4 steel screws  
Recommended fastening torque 2.8 N·m
- Connection of secondary on D-SUB-9, UNC 4-40
- All mounting recommendations are given for a standard mounting. Screws with flat and spring washers.
- Primary through hole  $\varnothing \leq 26\text{ mm}$
- Installation of the transducer must be done unless otherwise specified on the datasheet, according to LEM Transducer Generic Mounting Rules. Please refer to LEM document N°ANE120504 available on our Web site: [Products/Product Documentation](#).