

For the electronic measurement of current: DC, AC, pulsed..., with galvanic separation between the primary and the secondary circuit.

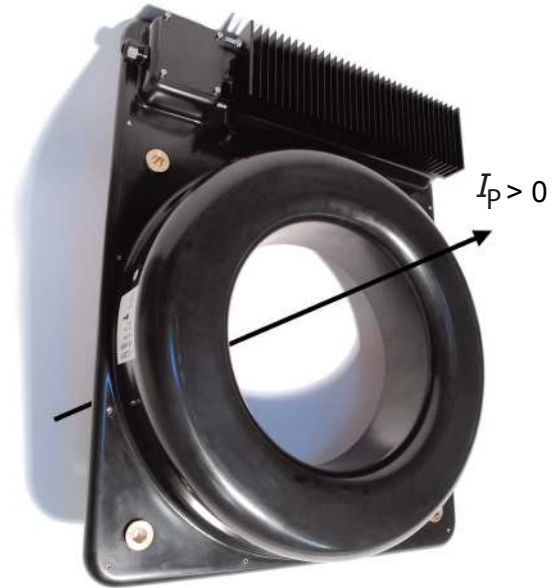

RoHS



Features

- Closed loop (compensated) current transducer
- Current output
- Bipolar supply voltage
- Accuracy Class 0.2S (IEC 61869-2)
- Ingress protection rating IP54.

Advantages

- Integrated design
- Low cost
- Large aperture.

Applications

- HVDC (VSC Technology)
- Medium voltage PFC and active filters
- Small DC component detection in large AC currents (transformer protection).

Standards

- IEC 61010-1: 2010
- ¹⁾ IEC 61869-1: 2007
- ¹⁾ IEC 61869-2: 2012
- ¹⁾ IEC 61869-6: 2016.

Application Domain

- Industrial.

Note: ¹⁾ Performance standards: ITL 4000-S only partially fulfills these standards as this flux-gate transducer has fundamental difference compared to current transformers.

Absolute maximum ratings

Parameter	Symbol	Unit	Value
Maximum supply voltage	$U_{C\ max}$	V	±30
Maximum primary conductor temperature	$T_{B\ max}$	°C	70

Stresses above these ratings may cause permanent damage. Exposure to absolute maximum ratings for extended periods may degrade reliability.

Insulation coordination

Insulation between primary and secondary + shield

Parameter	Symbol	Unit	Value	Comment
Rated insulation RMS voltage, reinforced insulation	U_b	V	1000	According to IEC 61010-1 CAT III, PD2
Rated insulation RMS voltage, reinforced insulation (highest voltage for equipment)	U_b	V	1200	According to IEC 61869-1
RMS voltage for AC insulation test, 50 Hz, 1 min	U_d	kV	6.4	
Impulse withstand voltage 1.2/50 μ s	\hat{U}_W	kV	16.5	
Clearance (pri. - sec.)	d_{Cl}	mm	> 130	Shortest distance through air
Creepage distance (pri. - sec.)	d_{Cp}	mm	> 200	Shortest path along device body
Case material	-	-	V0	According to UL 94
Comparative tracking index	CTI		600	

Insulation between shield and secondary

Parameter	Symbol	Unit	Value	Comment
RMS voltage for AC insulation test, 50 Hz, 1 min	U_d	kV	2.7	
Clearance (pri. - sec.)	d_{Cl}	mm	> 4	Shortest distance through air
Creepage distance (pri. - sec.)	d_{Cp}	mm	> 5.5	Shortest path along device body

Environmental and mechanical characteristics

Parameter	Symbol	Unit	Min	Typ	Max	Comment
Ambient operating temperature	T_A	°C	-40		70	
Ambient storage temperature	T_S	°C	-40		70	
Aperture diameter		mm	265	268		
Dimensions (W × H × D)		mm		500 × 643 × 118		
Mass	m	kg		40		

Electrical data

At $T_A = 25\text{ °C}$, unless otherwise noted.

Parameter	Symbol	Unit	Min	Typ	Max	Comment
Primary nominal RMS current	I_{PN}	A		4000		
Primary current, measuring range	I_{PM}	A	-12000		12000	
Secondary current	I_S	A	-4.8	1.6	4.8	
Number of secondary turns	N_S			2500		
Supply voltage	U_C	V	± 22.8	± 24	± 25.2	
Current consumption	I_C	A		$0.22 + I_S$	$0.35 + I_S$	
Measuring resistance	R_M	Ω	0		1	@ I_{PM} , $T_{CU} = 100\text{ °C}$, cable resistance included (see fig. 1 and 2)
Electrical offset current	I_{OE}	mA	-0.1		0.1	
Temperature variation of I_O	I_{OT}	mA	-0.1		0.1	-40 °C ... 70 °C
Sensitivity error	ε_G	%	-0.04		0.04	
Linearity error	ε_L	% of I_{PN}	-0.01		0.01	
Magnetic offset current ($5 \times I_{PN}$) referred to primary	I_{OM}	mA	-0.2		0.2	
Output RMS noise current 0.1 Hz ... 10 kHz referred to primary	I_{no}	A		0.5		Input referred, RMS
Reaction time @ 10 % of I_{PN}	t_{ra}	μs			2	@ I_{PN} , 100 A/ μs
Step response time to 90 % of I_{PN}	t_r	μs			10	@ I_{PN} , 100 A/ μs
Frequency bandwidth ($\pm 1\text{ dB}$)	BW	kHz		50		@ I_P RMS = 40 A, $R_M = 50\ \Omega$
Overall accuracy	X_G	% of I_{PN}	-0.06		0.06	
Overall accuracy	X_G	% of I_{PN}	-0.08		0.08	-40 °C ... 70 °C
Total error from $I_{PNDC} = -10\text{ A}$ up to $+10\text{ A}$		A	-1		1	$T_A = -25\text{ °C} \dots 50\text{ °C}$ $I_{PNAC} = I_{PN}$, max. 100 Hz

Definition of typical, minimum and maximum values

Minimum and maximum values for specified limiting and safety conditions have to be understood as such as well as values shown in "typical" graphs.

On the other hand, measured values are part of a statistical distribution that can be specified by an interval with upper and lower limits and a probability for measured values to lie within this interval.

Unless otherwise stated (e.g. "100 % tested"), the LEM definition for such intervals designated with "min" and "max" is that the probability for values of samples to lie in this interval is 99.73 %. For a normal (Gaussian) distribution, this corresponds to an interval between -3 sigma and +3 sigma. If "typical" values are not obviously mean or average values, those values are defined to delimit intervals with a probability of 68.27 %, corresponding to an interval between -sigma and +sigma for a normal distribution. Typical, maximal and minimal values are determined during the initial characterization of the product.

Maximum measuring resistance (included cable) versus measuring range

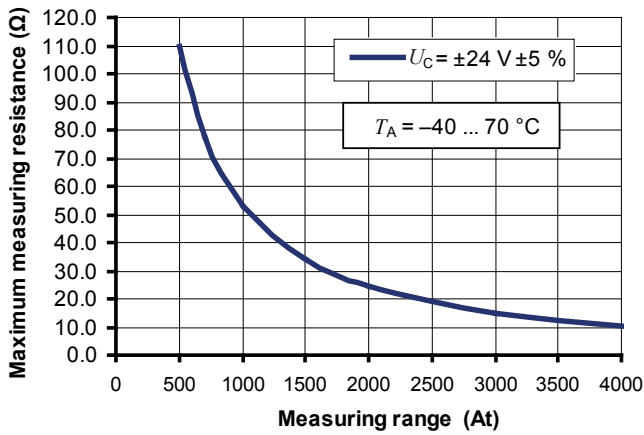

Figure 1: R_M for ranges 0 ... 4000 A

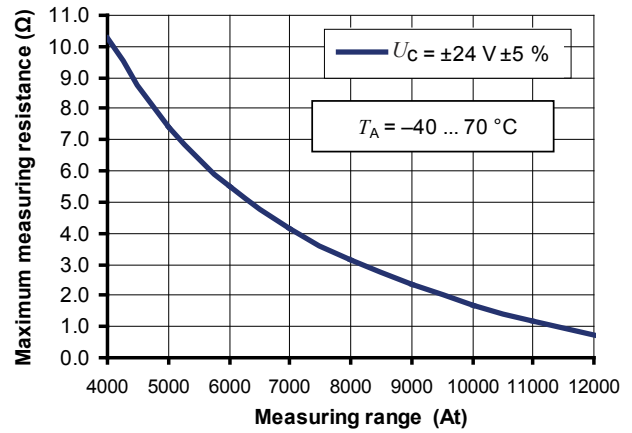

Figure 2: for ranges 4000 ... 12000 A

Typical Bandwidth @ $I_p = 40$ A

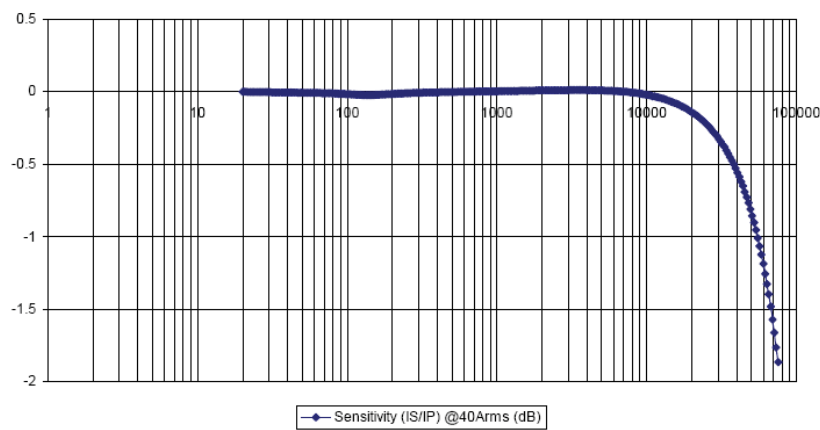

Figure 3: Bandwidth

Typical step response

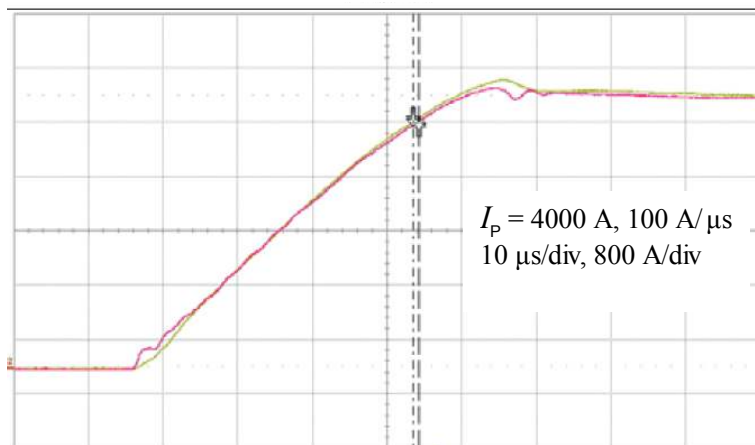

Figure 4: Step response di/dr

Installation

Mounting

The ITL 4000-S transducer should be mounted on a flat surface with its flat side against the surface. The IP54 degree of protection is guaranteed only if the ITL 4000-S transducer is mounted in a vertical position with the heatsink towards the top. In any case, the best thermal dissipation is obtained when the fins of the heatsink are oriented vertically. The transducer should be mounted with four screws complying with the inner diameter of the 4 bushings.

Connection

Remove the 4 screws that hold the small cover near the heatsink (see fig. 8). The tightening torque for these 4 screws is 1.3 N·m. The torque for the cable gland is 2.5 N·m. Cable gland is foreseen for a cable diameter 5.5 to 12 mm. Connection wires to the terminal block shall be from 0.2 mm² to max. 4 mm² (AWG24 to AWG12).

The tightening torque for the screws of the contact block is 0.7 N·m.

The ITL 4000-S transducer should be powered from a typical +24–24 V power supply, the positive voltage connected to + U_c (terminal 1), the negative voltage to – U_c (terminal 3). Supply ground is not connected to the transducer. The measuring resistance R_M should be connected between M (terminal 4) and ground (0 V) (see fig. 5).

Before a primary current is applied to the ITL 4000 transducer, the secondary circuit has to be closed; this means that a burden resistance and a power supply unit **must be connected**. This power supply must be able to limit the voltage at the maximum specified voltage rating, even if a secondary current is injected (because of transformer effect) and even if this power supply is not powered.

The heatsink and the measuring head are internally connected to the ground terminal (threaded stud) which is accessible on the heatsink side (see fig. 8); it should be connected to the ITL 4000-S local ground.

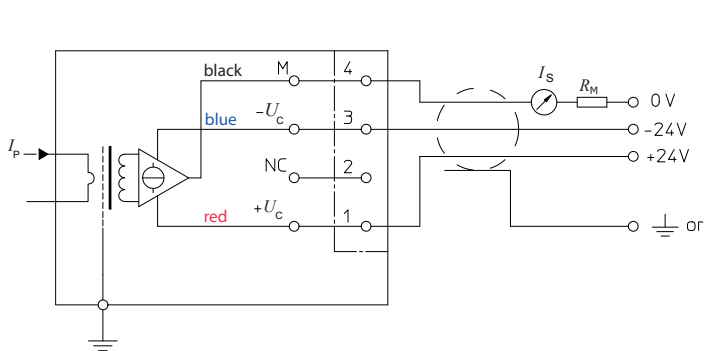
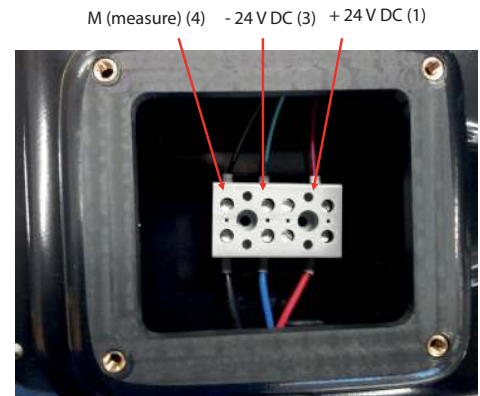

Figure 5: Connection principle



Customer side

When the distance between the ITL 4000-S and the control device is long, a double screened cable should be used and connected as shown in the schematics below. The external cable screen should be connected to the ITL 4000-S ground; the internal cable screen should be connected to the ground potential which is close to the control device.

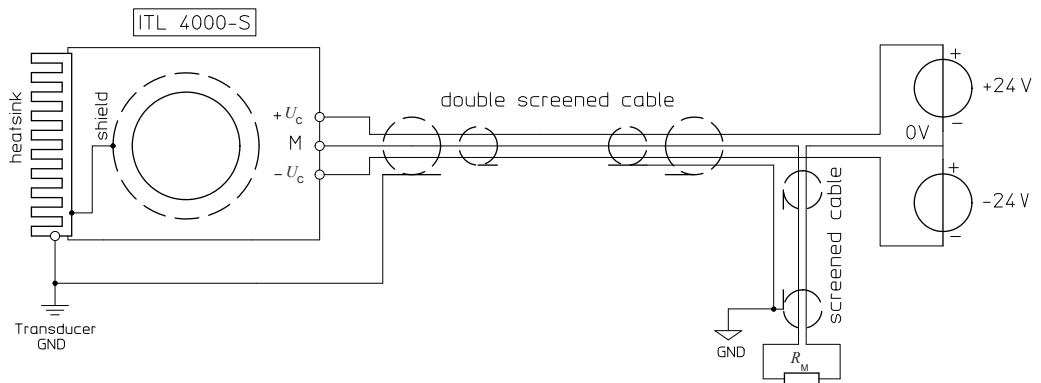

Figure 6: Double screened cable for long connection

Electronics module replacement procedure

1.1 Removing of the old electronics module

The electronics module (LEM reference 93.47.35.001.0) consists of the heatsink and the printed circuit board assembly which is pre-adjusted during manufacturing.



Figure 7: Electronics module of ITL 4000-S

The following procedure has to be followed:

- o Make sure that the primary current has been switched off.
- o Turn off the input power of the 24 V power supply. It is mandatory not to open the power supply connections to the transducer. See also recommendations under paragraph "Connection".
- o Remove the 6 screws that hold the heatsink (see fig. 8).
- o Electronics module can be moved away from the housing by pulling out the heatsink (you may use some more force).
- o Please make attention to the wires inside that are connected to the nearby box (you should start by the side opposite to the connection box and pull it out for around 5 cm).
- o When the module is open, you will have an access to the wires and one pin connectors.



Figure 8: External view of ITL 4000-S

- o Short-circuit the secondary winding of the transducer by engaging the two one pin connectors on the leads to the measuring head (fig. 9).
- o Remove the three leads on Connector X1 (fig. 11), the six leads on connector X2 (fig. 12) and the shield connection to the heatsink (fig. 12).

1.2 Installation of the new electronics module

- o Connect the new electronics module (colors as in fig. 11 and 12). Mounting torque for the earth connection screw is 0.55 N·m; mounting torque for the terminal screws (3 and 6 leads) is 0.5 N·m.
- o Remove the secondary winding short circuit by disconnecting the one pin connectors (fig. 10).
- o Put the heatsink in place (take care not to pinch any leads between heatsink and case) and fasten the 6 screws with a torque of 1.3 N·m.
- o Turn on the input power of the 24 V power supply unit.
- o The ITL 4000 transducer is now operating.

The electronics module is tested and adjusted before the shipment, therefore the expected accuracy of the ITL 4000 transducer with the new electronics module will respect requirements specified in the datasheet

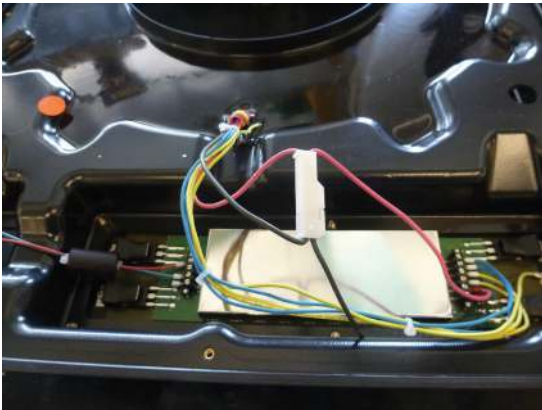

Fig. 9: Short circuit the secondary winding

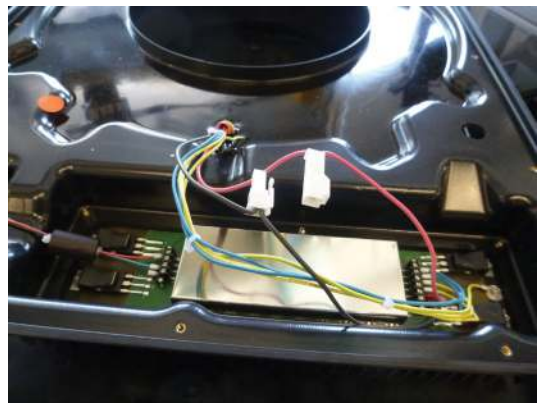

Fig. 10: Remove the secondary winding short circuit

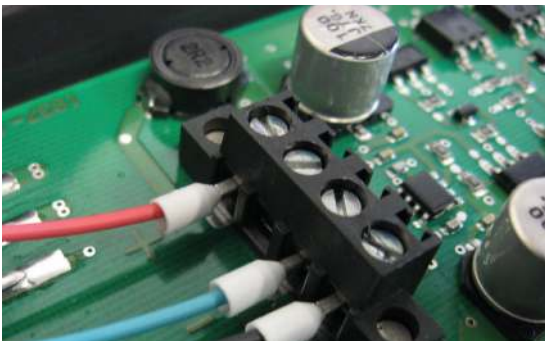

Fig. 11: Connector X1

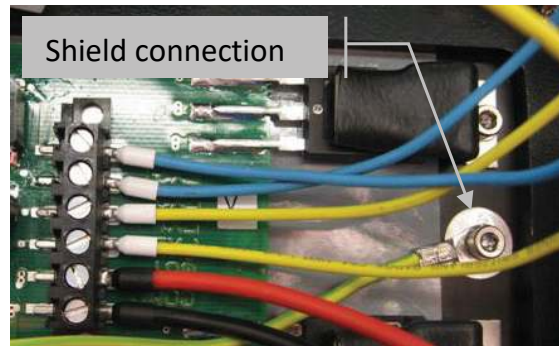
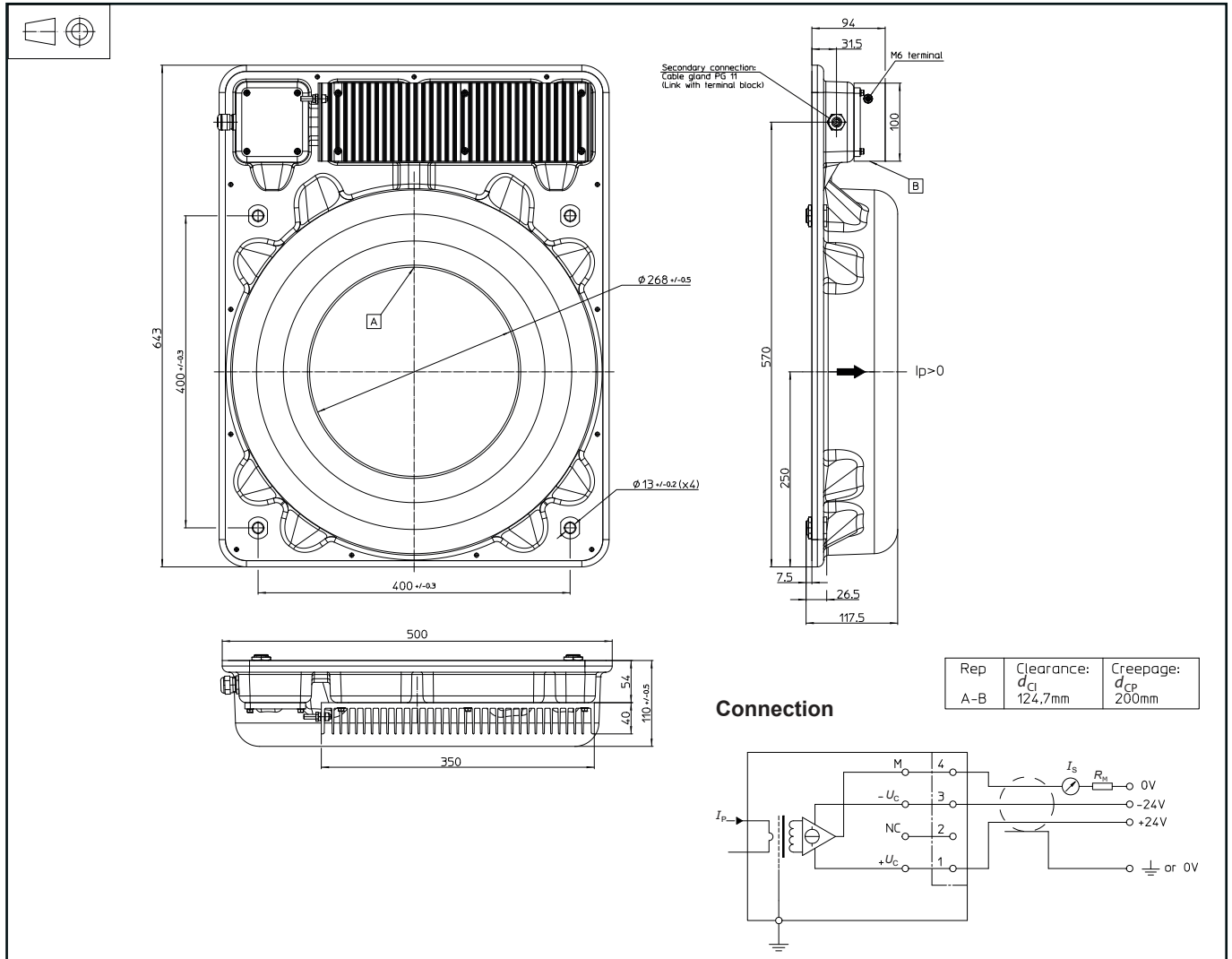

Fig. 12: Connector X2 and shield connection

Dimensions (in mm)



Mechanical characteristics

- General tolerance ± 1 mm
- Transducer fastening by spacers 4 holes $\phi 13$ mm
4 M12 steel screws
Recommended fastening torque 17 N·m
- Secondary link Connection cable block
on terminal Internal acces by lid

Remarks

- Installation of the transducer must be done unless otherwise specified on the datasheet, according to LEM Transducer Generic Mounting Rules. Please refer to LEM document N°ANE120504 available on our Web site: [Products/Product Documentation](#).

Safety



This transducer must be used in electric/electronic equipment with respect to applicable standards and safety requirements in accordance with the manufacturer's operating instructions.



Caution, risk of electrical shock

When operating the transducer, certain parts of the module can carry hazardous voltage (eg. primary busbar, power supply). Ignoring this warning can lead to injury and/or cause serious damage. This transducer is a build-in device, whose conducting parts must be inaccessible after installation. A protective housing or additional shield could be used. Main supply must be able to be disconnected.